

Transmission ITP

Emergency Procedures

PJM State & Member Training Dept.

Students will be able to:

- Describe PJM's overall approach to implementing Emergency Procedures
- Identify some triggers that may require PJM to initiate Conservative Ops
- Identify PJM and Member actions that will be taken once PJM initiates:
 - Conservative Ops
 - Voltage Control Emergency Procedures
 - Capacity Emergency Procedures

Emergency Procedures

Emergency Procedures Introduction

- An *emergency* in PJM is defined as:
 - An abnormal system condition requiring manual or automatic action, to:
 - Maintain system frequency
 - Prevent loss of firm load, equipment damage or tripping of system elements
 - Ensure the safety of persons or property
 - Maintain the reliability of the electric system
 - A fuel shortage requiring departure from normal operating procedures
 - Abnormal natural events or man-made threats to reliability
 - Including events external to PJM that may require PJM action

Emergency Procedures Introduction

- 4 levels of emergency procedures:

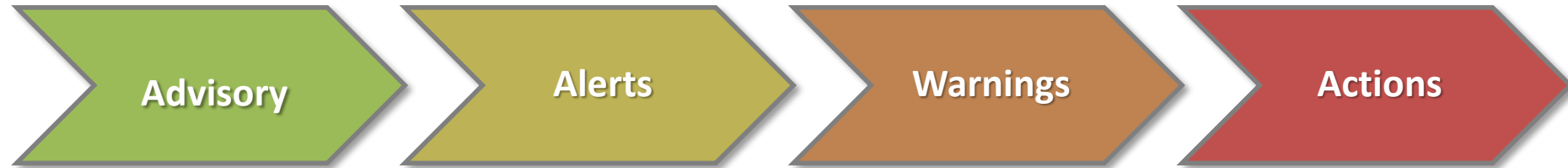

- Most Advisories, Alerts, Warnings and Actions are communicated via:
 - PJM ALL-CALL
 - Posted to various PJM websites
- Advisories and Alerts are issued in advance of the operating day
- Warnings and Actions are issued during the operating day

Emergency Procedures Introduction

- The PJM dispatcher has the flexibility to:
 - Implement emergency procedures in whatever order is required
 - Exit the emergency procedures in a different order than they are implemented when necessary
- PJM members are expected to implement all emergency procedures immediately
 - Desired relief expected within 30 minutes, unless directed otherwise

Emergency Procedures Introduction

Implementation of Emergency Procedures

- During unconstrained operations:
 - Implemented jointly across all PJM Control Zones, with the exception of Manual Load Dump
 - Manual Load Dump
 - Capacity deficient zone sheds load
 - If all zones are deficient, load shed is implemented proportionally based on level of shortage
- Transmission constraints:
 - May require implementation on a Control Zone basis

NERC Energy Emergency Alerts (EEAs)

- Alerts issued by Reliability Coordinator (RC) to ensure that all RCs understand potential and actual energy emergencies
 - Provides common terminology to use when explaining energy emergencies to each other
- Issued for capacity and energy shortages
 - Issued via the Reliability Coordinators Information System (RCIS)
- Three Levels
 - Levels may be declared in whatever order necessary, no need to proceed sequentially

NERC Energy Emergency Alerts (EEAs)

- **EEA Level 1 – All Available Resources in Use**

- Issued when a Control Area “foresees or is experiencing conditions where all available resources are committed”
- Concern about being able to sustain required Operating Reserves

- When does PJM issue?

- Maximum Generation Emergency Alert

NERC Energy Emergency Alerts (EEAs)

- **EEA Level 2 – Load Management Procedures in Effect**

- Issued when a Control Area “foresees or has implemented procedures up to but excluding interruption of firm load commitments”
 - Public Appeals, Voltage Reduction, Load Management, Interruption of Non-firm contracts

- When does PJM issue?

- Emergency Mandatory Load Management Reductions Action, a Voltage Reduction Action, or a Deploy All Resources Action (whichever issued first)

NERC Energy Emergency Alerts (EEAs)

- **EEA Level 3 – Firm Load Interruption Imminent or In Progress**
 - Issued when a Control Area “foresees or has implemented firm load obligation interruption”
 - Prior to declaring:
 - All generation on-line, regardless of cost
 - All purchases made, regardless of cost
 - All non-firm sales recalled
 - All contractually interruptible load curtailed
- When does PJM issue?
 - Manual Load Dump Action

Conservative Operations

Triggers for Conservative Operations

- Certain events, conditions, or circumstances may put the Bulk Electric System (BES) at an increased level of risk, compared to normal operating conditions
- In these situations, PJM – as the Reliability Coordinator – must implement additional actions to ensure the BES remains reliable in the face of the additional threats

Triggers for Conservative Operations

- Some conditions which may trigger PJM to implement Conservative Operations include;
 - Fuel Delivery Issues
 - Ice/snow impacting fuel deliveries
 - Possible curtailments of Natural Gas supplies
 - Forest or Brush Fires
 - Smoke from the fires can cause lines above them to short to ground
 - Environmental Alerts
 - Emissions limits may affect the output of older units
 - Bad Weather
 - Thunderstorms
 - Extreme heat or cold

Triggers for Conservative Operations

- Conditions triggering Conservative Operations (*con't*):
 - Geomagnetic Disturbances (GMDs)
 - High Altitude Electromagnetic Pulse
 - Terrorist or Sabotage **threats** against the BES
 - Including recent copper theft events
 - **Actual attacks** against physical or cyber assets critical to the operation of the BES
 - Substation equipment
 - Company EMS components
 - PJM entering an “unknown operating state,” as defined by NERC.

Triggers for Conservative Operations

- We will discuss general actions PJM can take when implementing Conservative Operations, as well as specific actions to address specific triggers
 - PJM has a variety of additional actions available, depending on which trigger has initiated the need for Conservative Operations

PJM Actions During Conservative Operations – General

General Actions:

- PJM will analyze power flows into, across and through the PJM control area to determine if it is in jeopardy
 - PJM’s most critical limits are the Interconnection Reliability Operating Limits (IROLs), which are determined by flows across the system
 - Transfer Limits can be reduced
 - Contracts may be suspended or cut
 - TLRs may be issued

PJM Actions During Conservative Operations – General

- **General Actions** *(con't)*:

- PJM may initiate additional off-cost operations to limit or reduce flows across critical interfaces
- PJM may purchase (or load) additional reserves, making more resources available to respond to any unexpected events

PJM Actions During Conservative Operations – General

- **General Actions** *(con't)*:

- PJM may look at the possibility of losing multiple pieces of equipment simultaneously
 - Normal operation – PJM studies single contingencies
 - May look at selected double contingencies (shared right-of-way)
 - May look at “Maximum Credible Disturbances”
 - If the analysis shows vulnerability, PJM may take additional actions to allow the system to survive these events
 - Load additional reserves
 - System reconfiguration
 - Additional off-cost operation

PJM Actions During Conservative Operations – General

- **General Actions** *(con't)*:

- PJM may implement an additional layer of security on communications with and between members
 - May require additional verification with members when issuing instructions or responding to reports
 - May increase the frequency of Satellite Phone checks
- PJM may ask for additional updates on system status
 - More frequent IRCs and/or RRCs
 - More frequent SOS Conference calls
- PJM may ask members to staff their back-up control centers, critical BES Substations, or black start facilities

Member Company Actions During Conservative Operations – General

- As with all emergency conditions, PJM expects that Member companies will comply with and follow the specific requests and direction of PJM during these events
 - Provide additional reporting data
 - Man substations or generating plants
 - Follow PJM operational directives (Transmission) or dispatch signals (Generation)

Fuel Delivery Emergencies

Conservative Operations – Fuel Delivery Emergencies

- Not only PJM, but RTOs and ISOs throughout North America have been affected by natural gas curtailments during cold weather periods
 - When natural gas supply or deliverability issues occur during cold weather:
 - Gas companies must give priority to heating over power generation
 - This has led to some generating plants being unavailable to generate during heavy load periods

Conservative Operations – Fuel Delivery Emergencies

- In conjunction with NYISO and ISO-NE, PJM has developed and maintains an RTO Natural Gas Coordination Procedure
 - The 3 RTOs will communicate jointly with Natural Gas Suppliers and the operators of Interstate Gas pipelines to manage potential inadequacy situations
 - Each RTO has developed a database of natural gas infrastructure in its footprint, including;
 - Location of units fueled by natural gas
 - Interstate pipeline supplier or LDC
 - Connection point on gas pipeline system
 - Contract arrangements for gas supply and transmission
 - Complete set of maps of the gas lines serving its system
 - Contact list for suppliers

Conservative Operations – Fuel Delivery Emergencies

- RTO Natural Gas Coordination Procedure (*con't*):
 - The RTOs will work jointly to share all information and work with suppliers to determine the best overall use for limited gas resources
 - This larger picture view helps protect the Eastern Interconnection as a whole, ensuring resources are used to best protect the Interconnection, not an individual RTO

Conservative Operations - Fuel Delivery Emergencies

PJM Actions

- Monitor weather conditions and identify forecast conditions which could trigger the need for a Cold Weather Alert
- Analyze and forecast the need for natural gas-fired resources, given forecast weather conditions, and determine the need for invoking this procedure
- Request a conference call with ISO New England and New York ISO to request the invoking of the procedures

Conservative Operations - Fuel Delivery Emergencies

PJM Actions

- The RTOs will jointly communicate with the interstate pipelines to include:
 - Summary of the expected electrical demand and capacity conditions in the RTOs during the forecasted weather event
 - Expected need for the natural gas-fired generation
 - Contact information for the interstate pipelines within each RTO

Conservative Operations - Fuel Delivery Emergencies

PJM Actions

- Each RTO will follow up individually with each of its interstate pipeline suppliers in its respective area, requesting:
 - The operational status of the pipeline
 - The presence or anticipation of any Operational Flow Orders (OFOs) or other emergency procedures
 - An assessment of the pipelines ability to serve contracts for gas-fired generation through the expected duration of the weather event

Conservative Operations - Fuel Delivery Emergencies

PJM Actions

- After collecting pipeline data, the RTOs will share the information, reconvene, and determine actions to be taken to include:
 - A modification of the generation dispatch day-ahead to account for expected unavailability of gas-fired generation
 - A limitation of the granting of outages to maximize availability of generation resources
 - An adoption of conservative operations actions intended to mitigate risks associated with gas system contingencies or gas-fired generation unavailability

Conservative Operations – Fuel Delivery Emergencies

Additional PJM Actions

- Work with NYISO and ISO-NE to determine the need to implement these procedures
- Provide information to the interstate pipelines concerning the need for gas-powered generation:
 - to operate and request information concerning pipeline status, emergency procedures, and/or contract curtailments
- Take the information provided to develop a joint strategy to maximize use of the available resources among the RTOs

Conservative Operations – Fuel Delivery Emergencies

Additional PJM Actions (*con't*):

- Limit the granting of Generator Outages during these periods, to maximize availability
- Adopt Conservative Operations

Conservative Operations – Fuel Delivery Emergencies

Additional Member Actions

- Provide facility information on gas-fired generation
 - Gas Supplier
 - Data on physical connections to the Interstate gas supply system
- Inform PJM of any delivery limitations to their gas supply
- Notify PJM if voluntary pre-contingency fuel switching will be implemented
- Comply with any and all operational instructions issued by PJM

Geomagnetic Disturbances (GMDs)

Introduction to Geomagnetic Disturbances

- As part of its normal functioning, the sun puts off a constant stream of ionized particles – known as the solar wind – which streams out in all directions
- A portion of these ionized particles reach the earth, and interact with its magnetic field
 - Depending on the alignment of the charge on the particles, they are either deflected, or channeled to the north and south magnetic poles
 - Some of the particles interact in the atmosphere, causing the Northern (and Southern) Lights

Geomagnetic Disturbances

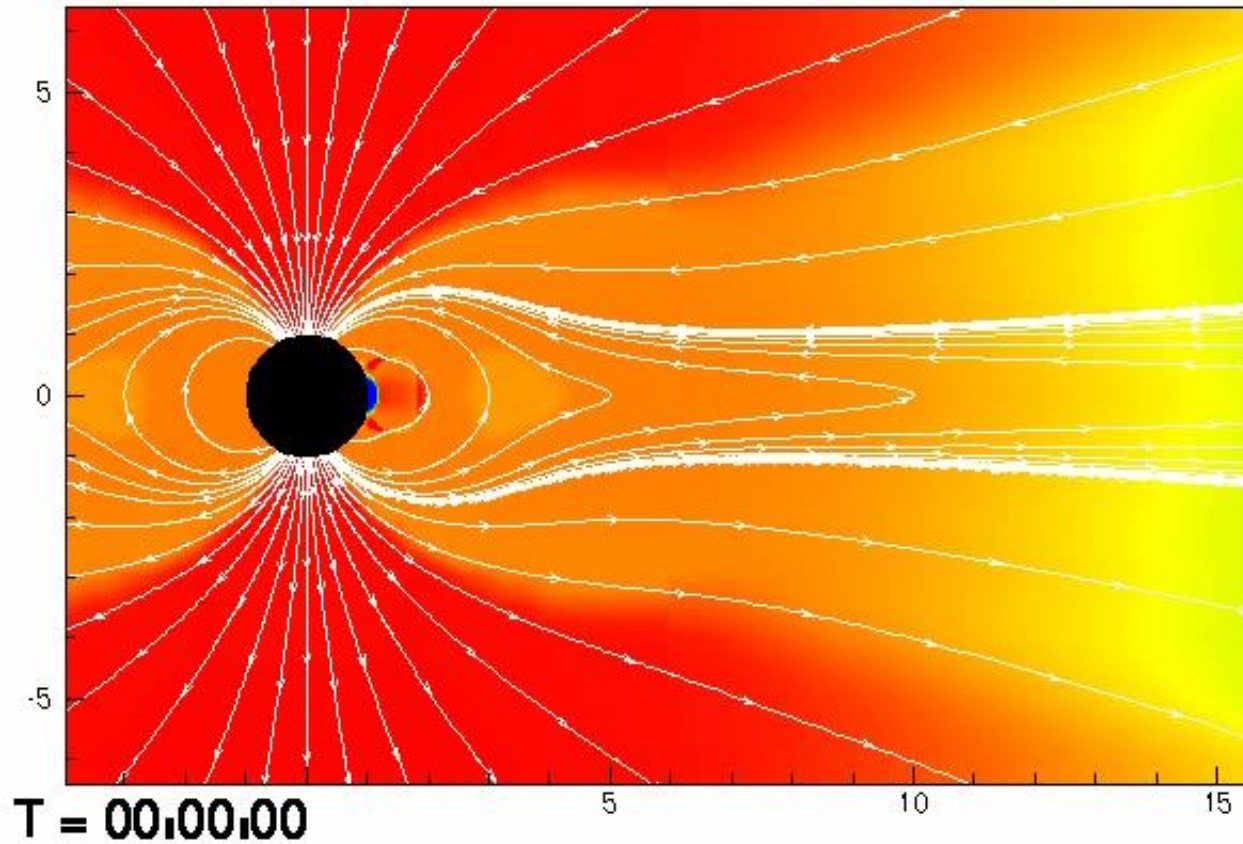

Space Hurricane

- Billions of tons of charged particles ejected by the sun
- Plasma cloud with its own magnetic field
- Takes 17 – 24 hours to reach Earth

Why Should We Care?

- Hydro-Quebec Blackout 1989:
 - 7 SVCs tripped
 - Transformer consume more MVARs
 - Loss of 21,500 MW of generation
 - 1 confirmed transformer damage: Salem's GSU
- Halloween Storm 2003:
 - Outages in Sweden
- Carrington event 1859
- Large CME 1921

CABLES DAMAGED BY SUNSPOT AURORA

Ships to Be Sent Out to Mend Lines Put Out of Service by Magnetic Display.



SUNSPOT CREDITED WITH RAIL TIE-UP

New York Central Signal System Put Out of Service by Play of Northern Lights.

The sunspot which caused the brilliant aurora borealis on Saturday night and the worst electrical disturbance in telegraph systems was unprecedented thing at erday morning, when and switching system Central Railroad below put out of operation, followed by a fire in the control tower at Fifty-seventh Street and Park Avenue. This is the first time that a sunspot has been blamed for such a piece of mischief. From other accounts it appeared

The New York Times
Published: May 16, 1921
Copyright © The New York Times

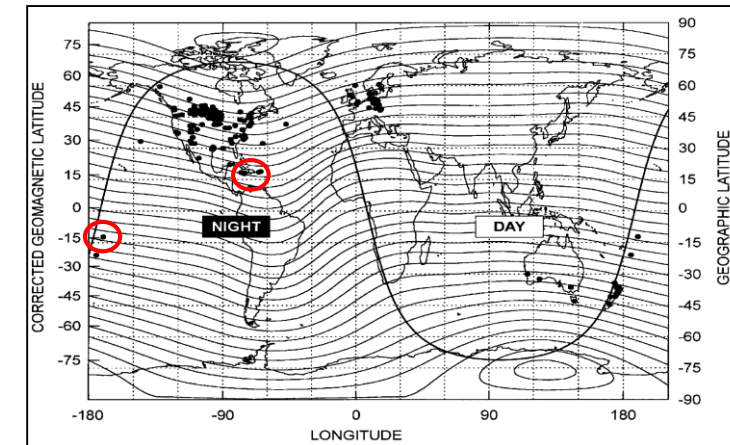

Locations for which aurora were reported on 14–15 May 1921 – Silverman, et al.

NOAA Forecasting: Coronagraphs

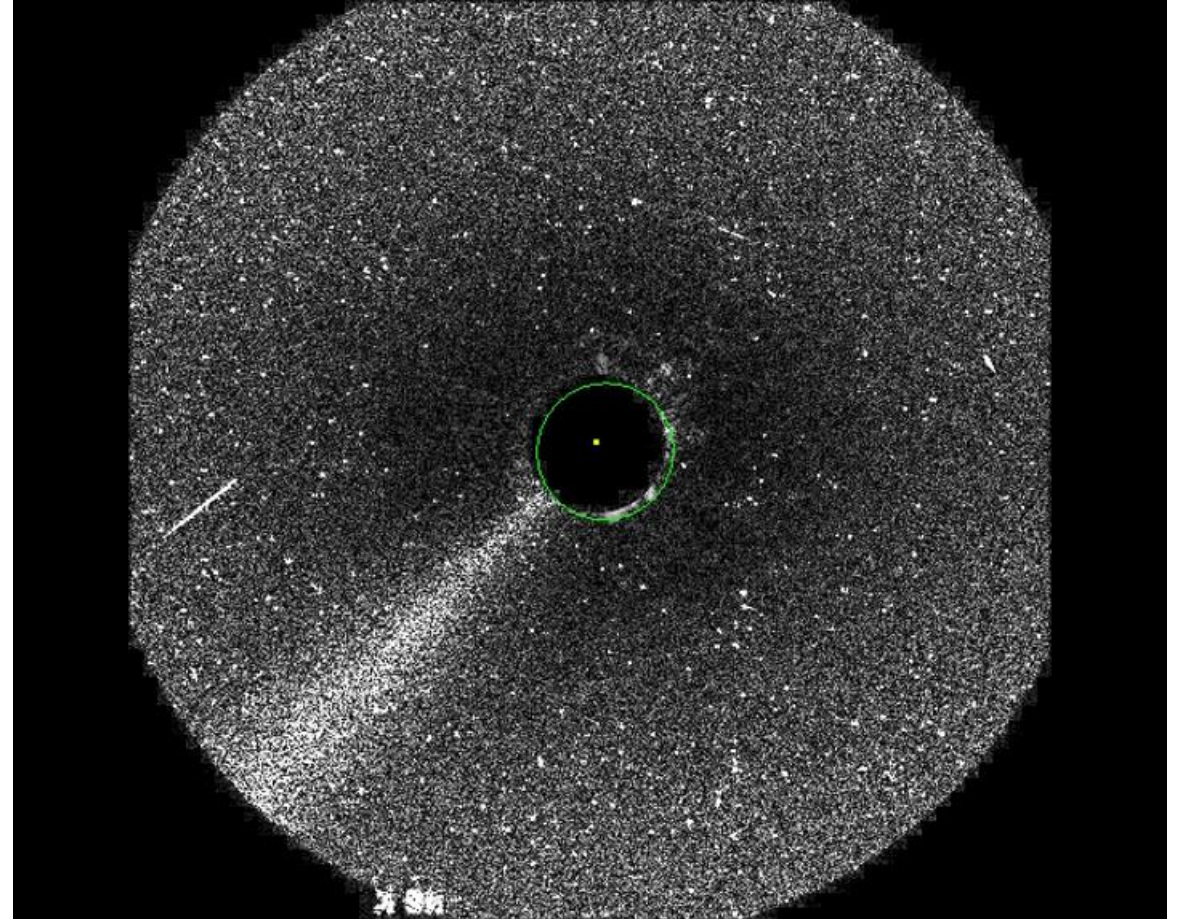
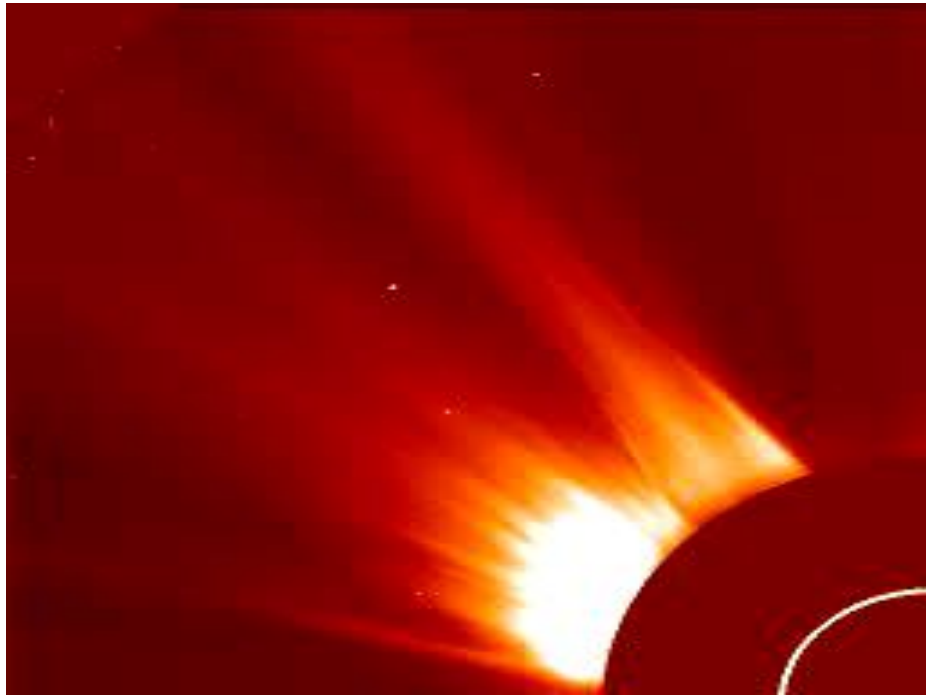

NOAA: Kp-Index (or G-scale)

- NOAA Forecast:
 - **Watch:** long term forecast (1 day ahead)
 - **Warning:** short lead time (hours ahead)
 - **Alert:** real-time activity
- PJM was the GMD monitor for Eastern Interconnection until January 31, 2017, now FRCC

K-index was not designed for power systems

Category		Effect	Physical measure	Average Frequency (1 cycle = 11 years)	
Scale	Descriptor	Duration of event will influence severity of effects			
Geomagnetic Storms					
Minor impact	G 5	Extreme	<p><u>Power systems:</u> widespread voltage control problems and protective system problems can occur, some grid systems may experience complete collapse or blackouts. Transformers may experience damage.</p> <p><u>Spacecraft operations:</u> may experience extensive surface charging, problems with orientation, uplink/downlink and tracking satellites.</p> <p><u>Other systems:</u> pipeline currents can reach hundreds of amps, HF (high frequency) radio propagation may be impossible in many areas for one to two days, satellite navigation may be degraded for days, low-frequency radio navigation can be out for hours, and aurora has been seen as low as Florida and southern Texas (typically 40° geomagnetic lat.).**</p>	Kp=9	4 per cycle (4 days per cycle)
	G 4	Severe	<p><u>Power systems:</u> possible widespread voltage control problems and some protective systems will mistakenly trip out key assets from the grid.</p> <p><u>Spacecraft operations:</u> may experience surface charging and tracking problems, corrections may be needed for orientation problems.</p> <p><u>Other systems:</u> induced pipeline currents affect preventive measures, HF radio propagation sporadic, satellite navigation degraded for hours, low-frequency radio navigation disrupted, and aurora has been seen as low as Alabama and northern California (typically 45° geomagnetic lat.).**</p>	Kp=8	100 per cycle (60 days per cycle)
	G 3	Strong	<p><u>Power systems:</u> voltage corrections may be required, false alarms triggered on some protection devices.</p> <p><u>Spacecraft operations:</u> surface charging may occur on satellite components, drag may increase on low-Earth-orbit satellites, and corrections may be needed for orientation problems.</p> <p><u>Other systems:</u> intermittent satellite navigation and low-frequency radio navigation problems may occur, HF radio may be intermittent, and aurora has been seen as low as Illinois and Oregon (typically 50° geomagnetic lat.).**</p>	Kp=7	200 per cycle (130 days per cycle)
	G 2	Moderate	<p><u>Power systems:</u> high-latitude power systems may experience voltage alarms, long-duration storms may cause transformer damage.</p> <p><u>Spacecraft operations:</u> corrective actions to orientation may be required by ground control; possible changes in drag affect orbit predictions.</p> <p><u>Other systems:</u> HF radio propagation can fade at higher latitudes, and aurora has been seen as low as New York and Idaho (typically 55° geomagnetic lat.).**</p>	Kp=6	600 per cycle (360 days per cycle)
	G 1	Minor	<p><u>Power systems:</u> weak power grid fluctuations can occur.</p> <p><u>Spacecraft operations:</u> minor impact on satellite operations possible.</p> <p><u>Other systems:</u> migratory animals are affected at this and higher levels; aurora is commonly visible at high latitudes (northern Michigan and Maine).**</p>	Kp=5	1700 per cycle (900 days per cycle)

Geomagnetic Disturbances

- By constructing the Bulk Electric System, we have inadvertently given these currents a much less resistant path to flow along
 - The vast majority of BES Power Transformers are connected in a grounded Wye-Delta configuration
 - The GICs in high ground resistance areas travel up the ground path into the BES Power Transformers, travel along the transmission lines, and return to the ground via a BES transformer ground path in the area of lower induced voltage potential

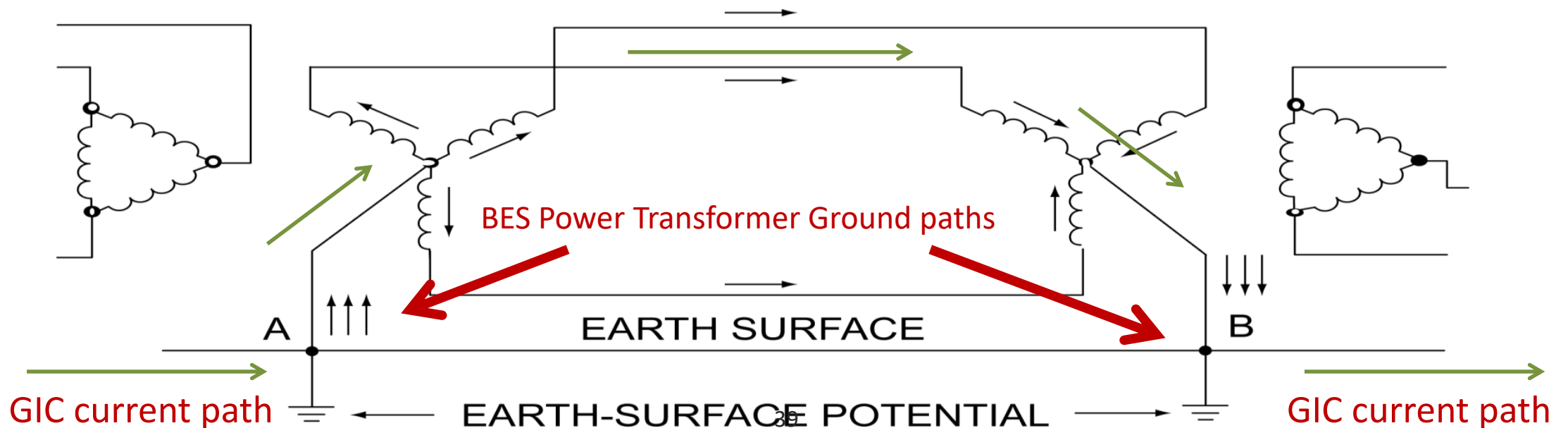

Geomagnetic Disturbances

- PJM has installed special monitoring to detect these currents at locations throughout the PJM RTO known to be prone to GIC activity
 - AEP
 - APS
 - BC
 - COMED
 - DOM
 - PE
 - PEP

Impacts of GMDs

Hot-spots

MVARs

Harmonics

- Transformer ½ Cycle Saturation
- Geomagnetically Induced Current (GIC):
 - Quasi-DC: <math><0.1\text{Hz}</math>
- Saturated Transformers
 - Hot spots form inside
 - Consume more MVARs
 - Harmonic source

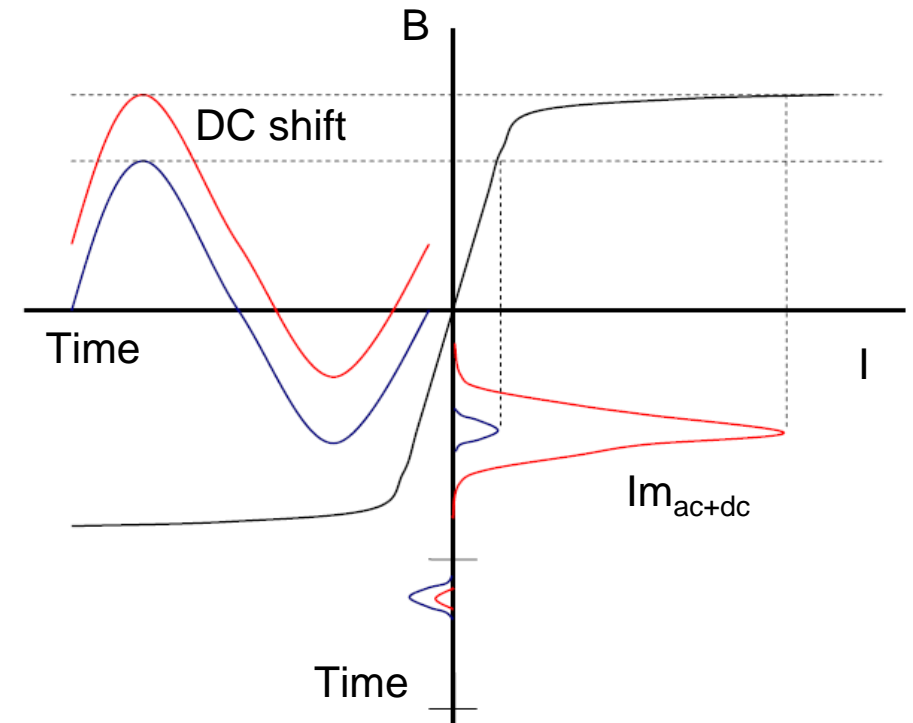

Transformer Hot-Spots

Hot-spots

MVARs

Harmonics

- Heating is not instantaneous
 - Rate-of-rise and final temperature are quite different for different active and structural parts
- Thermal analysis:
 - Ambient temperature
 - Loading condition
 - GIC

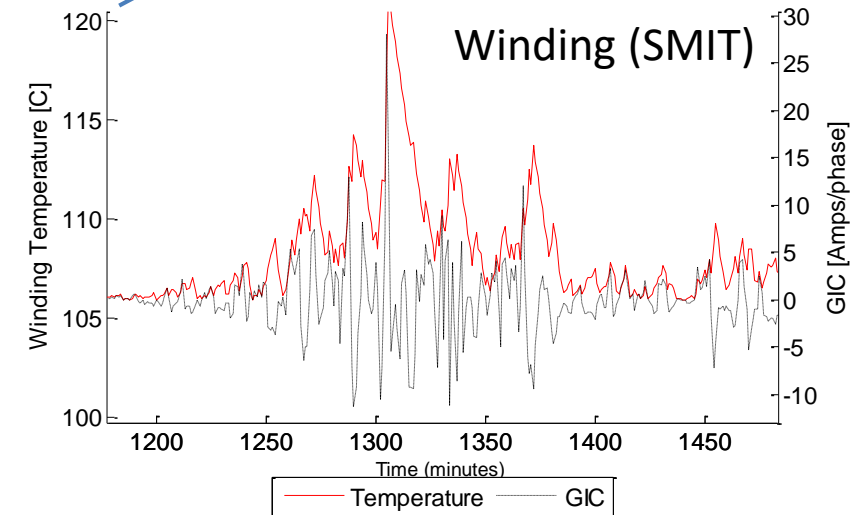
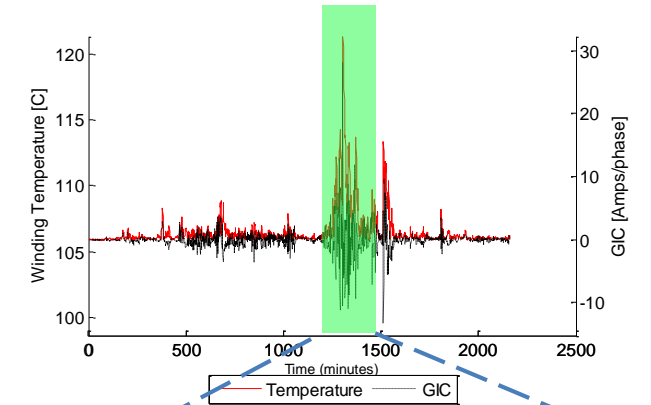
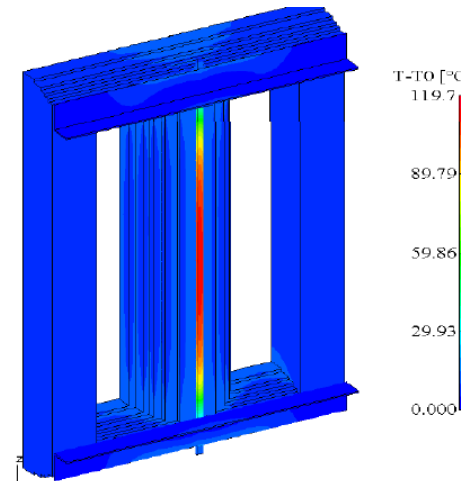

Voltage Stability

Hot-spots

MVARs

Harmonics

- Transformer consume extra reactive power:
 - Voltage stability
 - Potential issues with state estimator

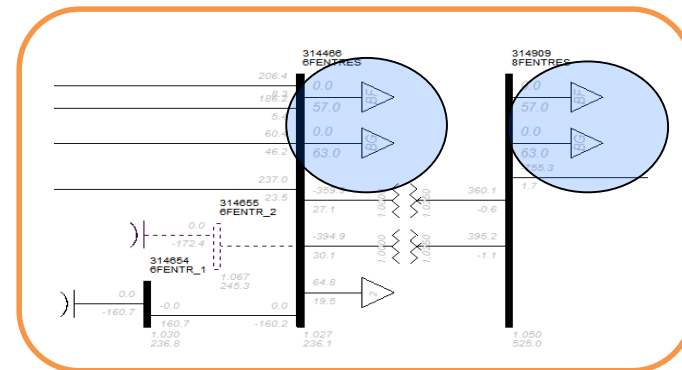
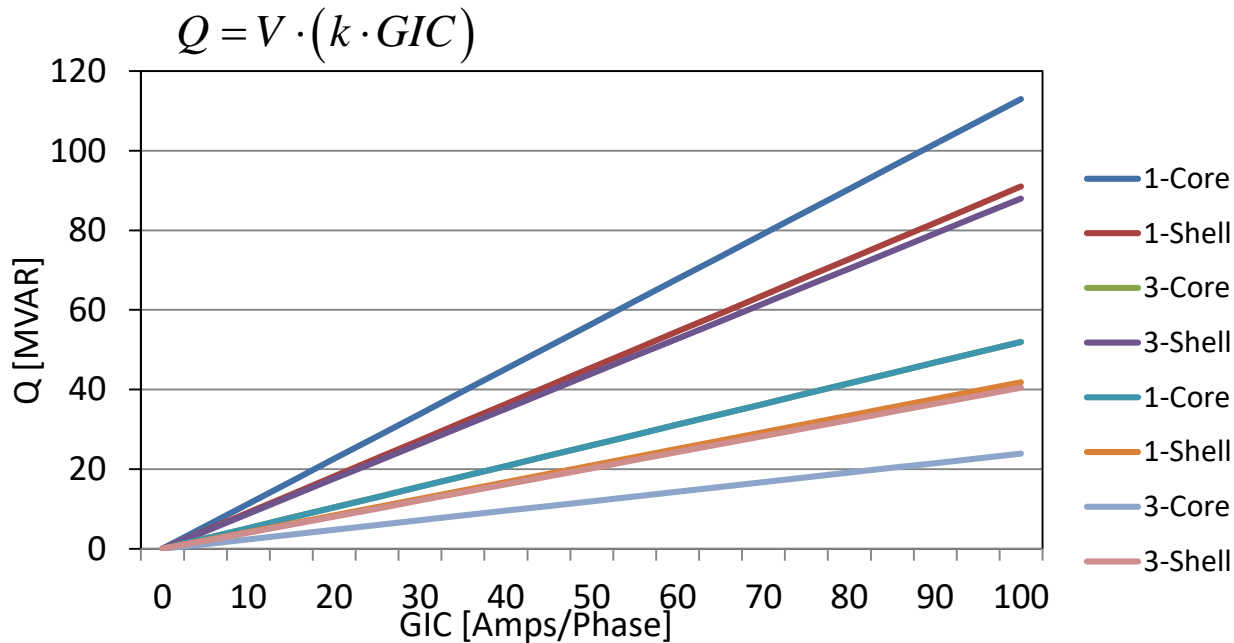
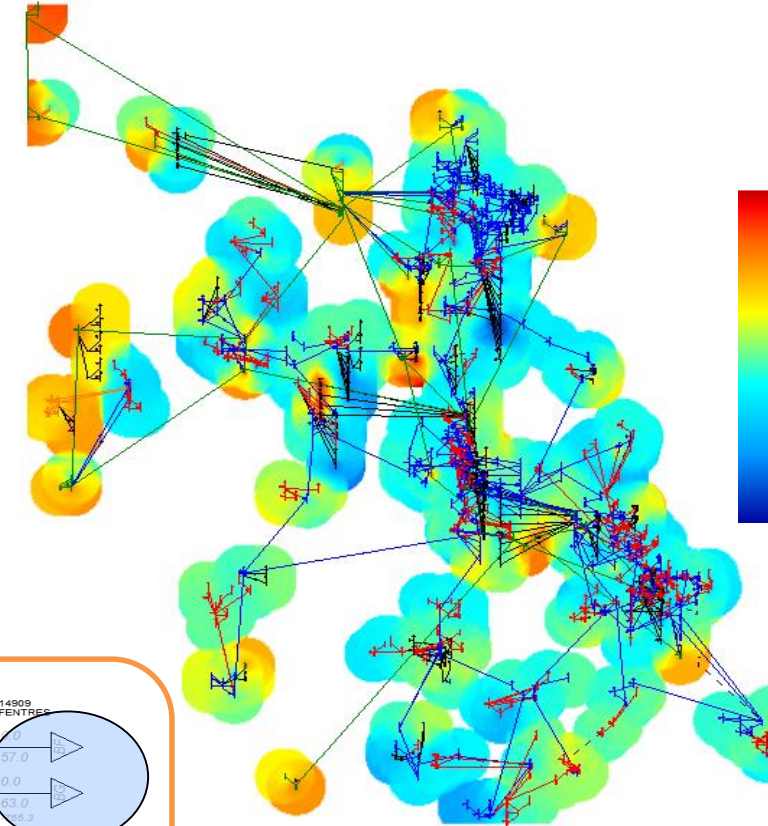

Impact of Harmonics

Hot-spots

MVARs

Harmonics

- Impact of harmonics:
 - Protection system and fuses
 - Generator negative sequence heating
 - Control devices

500 kV Voltage
B SVC/STATCOM

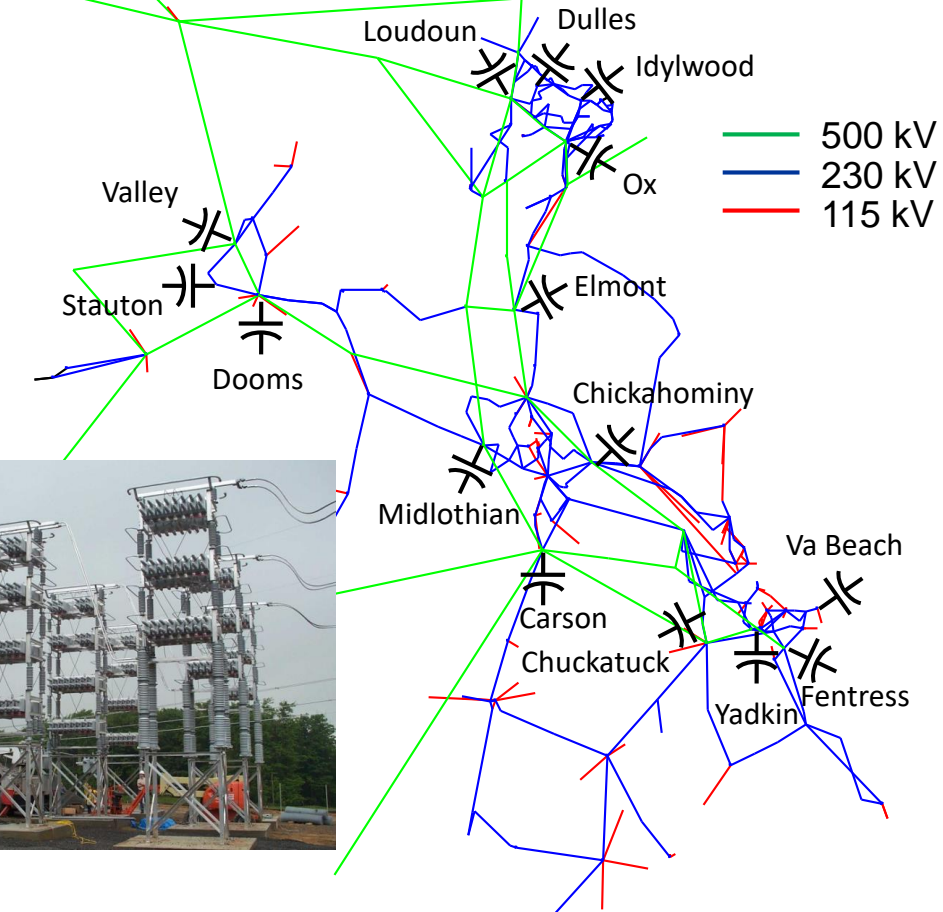
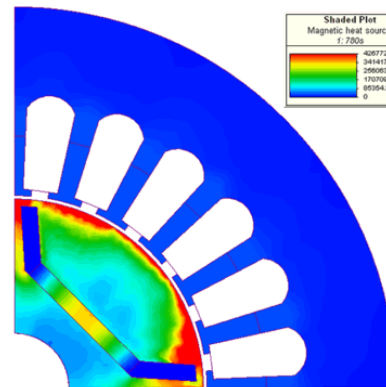
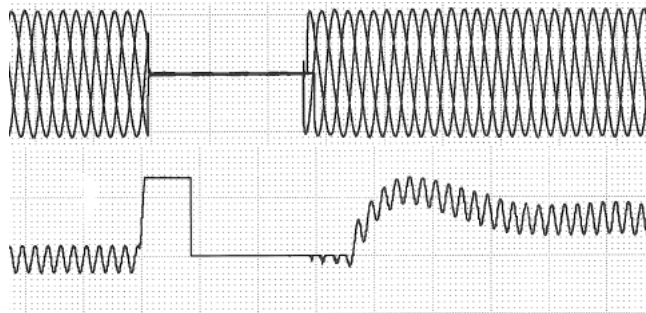

Harmonics caused 1989 Hydro-Quebec blackout

Standards: NERC EOP-010-1

- The purpose of NERC EOP-010-1 is to mitigate the effects of geomagnetic disturbance (GMD) events by implementing Operating Plans, Processes, and Procedures
 - Each RC shall develop, maintain, and implement a GMD Operating Plan and procedure
 - Each RC shall disseminate forecasted and current space weather

Standards: NERC TPL 007-1

- The purpose of NERC standard TPL-007-1 is to establish requirements for Transmission system planned performance during geomagnetic disturbance (GMD) events
 - Identify the individual and joint responsibilities of the Planning Coordinator and Transmission Planner(s) for maintaining models and performing studies needed to complete GMD Vulnerability Assessment(s)
 - Each identified party shall maintain System and GIC System models needed to complete GMD Vulnerability Assessment(s), including GID flow data

Corrective Action Planning: If there is a risk...we need to mitigate it

Corrective Action Plan/Planning

Hardening

- P&C upgrade
 - Capacitors
 - SVC/STATCOM
 - Generators
- Technical specifications
 - Transformers
 - Harmonic Filters
- Blocking devices

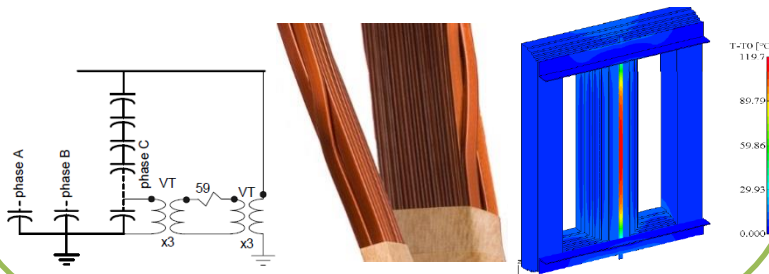

Situational Awareness

- NOAA forecast
- GIC monitors
- Magnetometers
- Harmonics
- Reactive power
- Thermocouples
- DGA



Operating Procedures

- Topology
- Cancel outages
- Generation dispatch
- Transformer cooling

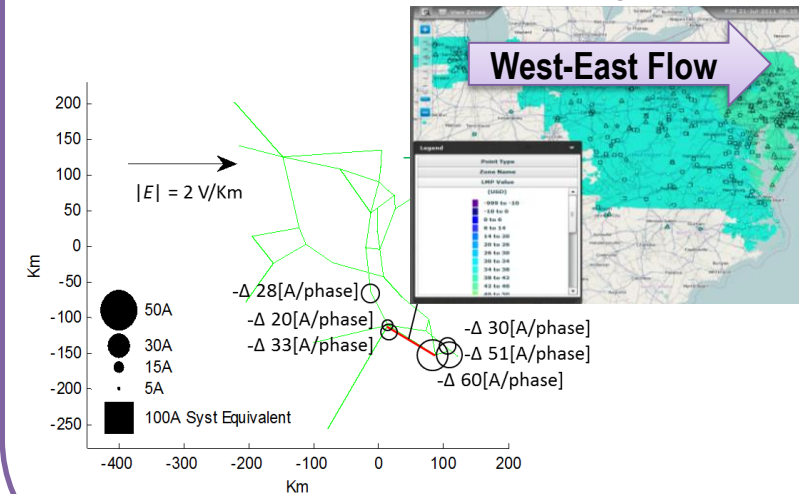

Geomagnetic Disturbance Warning

- If the National Oceanic and Atmospheric Administration (NOAA) issues a warning or an alert for a potential geo-magnetic storm of severity K7 or greater, PJM will provide notification via the All-Call system and Emergency Procedure Posting Application

Geomagnetic Disturbance Warning

PJM Actions:

- PJM dispatch notifies members (Generation and Transmission) via the PJM All-Call of GMD warnings/alerts issued by the National Oceanic and Atmospheric Administration (NOAA) via the RCIS and/or the NERC Hotline
- If GIC measurements exceed the associated GIC operating limit, in amperes, at one and only one of the transformers monitored for GIC flow, PJM dispatch confirms that this measurement is a result of a severe geomagnetic storm by contacting the TO or GO in order to verify that the readings are accurate

Geomagnetic Disturbance Warning

Member Actions:

- Transmission/Generation dispatchers provide confirmation of measurement values as requested by PJM dispatch
- Generation dispatchers provide as much advance notification as possible regarding details of more restrictive plant procedures that may result in plant reductions to protect equipment

Geomagnetic Disturbance Action

- PJM dispatcher may take action as soon as necessary for a GMD disturbance but must take action if conditions persist for 10 minutes
- If GIC measurements exceed the GIC Operating Limit at two or more transformers monitored for GIC flow, PJM dispatch contacts the TO(s) and GO(s) in order to verify the readings are accurate and determine if excess MVAR exist at area transformers.
- PJM also checks the NOAA GMD (<http://www.swpc.noaa.gov/>) to confirm if any storm warnings or alerts have been issued, but this confirmation is not required for implementation of procedures if measurements are indicative of a geomagnetic disturbance

Geomagnetic Disturbance Action

- Upon identification of a geomagnetic disturbance, PJM dispatch declares a Geomagnetic Disturbance Action and operates the system to geomagnetic disturbance (GMD) transfer limits. The geomagnetic disturbance transfer limits are determined from studies modeling various scenarios, including:
 - Partial or complete loss of Hydro Quebec Phase 2 DC line to Sandy Pond
 - Reduction or complete loss of generation at Artificial Island
 - Tripping of certain EHV capacitors

Geomagnetic Disturbance Action

PJM Actions:

- PJM dispatch notifies members (Generation and Transmission) and neighbors via the PJM All-Call, postings on selected PJM web-sites and the NERC RCIS of a Geomagnetic Disturbance Action to mitigate the effects of GMD events on the system
- PJM dispatcher begins to operate the system to the geomagnetic disturbance transfer limits
- To mitigate the effects of GMD events on the system, when the GMD transfer limit is approached or exceeded, generation re-dispatch assignments are made in the most effective areas to control this limit

Geomagnetic Disturbance Action

PJM Actions:

- If insufficient generation is available to control this limit, the emergency procedures contained in Section 2 are implemented
- If it appears that these emergency procedures are required, an operations engineer is requested to validate the GMD transfer limit and develop a voltage drop curve for the GMD transfer limit contingency
- Pre-contingency load dumping will not be used to control transfers to the GMD transfer limit

Geomagnetic Disturbance Action

PJM Actions:

- After GIC measurements at all monitored transformers have fallen below the GIC Operating Limit, PJM dispatch continues to operate the system to the geomagnetic disturbance transfer limits for a period of three hours
- PJM dispatch must again confirm this measurement by contacting TOs and GOs. If the measurement values are confirmed to remain below 10 amperes for three hours, members are notified that the Geomagnetic Disturbance Action is cancelled. PJM dispatch restores the appropriate transfer limits for operation of the system

Geomagnetic Disturbance Action

Member Actions:

- Upon notification of the implementation of this procedure, members that operate facilities with instrumentation installed to record GIC neutral measurements at remote locations dispatch personnel to ensure that measurement equipment working properly
- Members employing a MVAR summing algorithm method also initiate data collection at this time. It is requested that any data collected during a geomagnetic storm be forwarded to PJM for further analysis
- The member dispatchers report all actions to PJM dispatch

Geomagnetic Disturbance Action

Member Actions:

- Transmission Owners are not required to have GMD Operating Plans
- TOs that do have GMD Operating Plans are required to provide copies of those plans to PJM and are also required to coordinate any actions in their plans with PJM prior to implementation

Terrorism and Sabotage Emergencies

Conservative Operations – Terrorism and Sabotage

- Responses to any triggers include a multi-faceted plan to safeguard personnel and maintain interconnection reliability, including:
 - Power system operations
 - Communications
 - Cyber security
 - Physical security
- Emphasis is on operations and communications based upon the specific threat and intelligence
 - Actual response can be tailored to the event as needed

Conservative Operations – Terrorism and Sabotage

- Key PJM actions are based upon Threat Levels issued by the Department of Homeland Security (DHS)
 - DHS now uses the National Terrorism Advisory System (NTAS)
 - NTAS has 2 types of alerts;
 1. Elevated Threat Alert: Warns of a credible threat against the U.S.
 2. Imminent Threat Alert: Warns of a credible, specific and impending threat against the U.S.
 - These alerts are issued with a “sunset provision”, which means the alert will expire after a certain time
 - DHS can extend the alert if there is a valid reason to do so based on new or updated information

Terrorism and Sabotage

NTAS Alert Issued	Other Potential Triggers	PJM Actions-Operations	PJM Actions-Communications
<p data-bbox="366 482 486 522">None</p>	<ul data-bbox="759 482 1192 644" style="list-style-type: none"><li data-bbox="759 482 1192 644">• Suspicious activity reported by adjacent systems	<ul data-bbox="1337 482 1786 1168" style="list-style-type: none"><li data-bbox="1337 482 1786 644">• Remind all operators of increased vigilance<li data-bbox="1337 682 1786 1025">• PJM Operations Management will review and discuss this section of the Emergency Operations manual<li data-bbox="1337 1068 1786 1168">• Increased vigilance and reporting	<ul data-bbox="1905 482 2372 901" style="list-style-type: none"><li data-bbox="1905 482 2372 644">• PJM passes along credible/actionable intelligence<li data-bbox="1905 682 2372 901">• All operations centers should review reporting requirements

Terrorism and Sabotage

NTAS Alert Issued	Other Potential Triggers	PJM Actions-Operations	PJM Actions-Communications
<ul style="list-style-type: none">• Elevated Threat Level	<ul style="list-style-type: none">• Suspicious activity reported by adjacent systems• DHS/FBI issued a Threat Advisory	<ul style="list-style-type: none">• Maintenance outages are analyzed; equipment return times are verified• Maximum Credible contingencies analyzed by PJM Reliability Engineer• Increased vigilance and reporting• Analyze hydro schedules- to increase Black Start capability• Initiate Black Start Assessment- to determine fuel limitations (SSR)	<ul style="list-style-type: none">• Communicate threat through ALL-CALL• Satellite Phone checks (daily/weekly)• Enhance voice communications security• Enhance cyber security scanning• Additional SOS conference calls (no market information)• PJM staffs an Incident Response Team• If an attack occurs, notify members (ALL-CALL)

<p align="center">NTAS Alert Issued</p>	<p align="center">Other Potential Triggers</p>	<p align="center">PJM Actions-Operations</p>	<p align="center">PJM Actions-Communications</p>
<ul style="list-style-type: none"> • Imminent Threat Level 	<ul style="list-style-type: none"> • Cyber event has shut down control center EMS capability, or physical attack at multiple sites • Intelligence of an impending attack on a PJM facility • Cyber event has shut down control center EMS capability, or physical attack at multiple sites • Significant terrorist activity beyond the East Coast 	<ul style="list-style-type: none"> • Adopt more conservative modeling measures (double contingencies, maximum credible disturbances, or lower reactive transfer limits) • Increase Available Operating Reserve • Cancel selected Maintenance Outages –restore outaged equipment (No touch maintenance policy) • Consider staffing selected substations, critical CT sites, and black start units • Increase Synchronized Reserves • Obtain emergency energy bids • Enhance physical security at critical substations 	<ul style="list-style-type: none"> • Communicate threat over ALL CALL • Institute Daily Conference Calls • If cyber attack is occurring consider limiting internet accessibility • PJM maintains 24 hour Operations Management presence • Provide instructions to units to operate within a given set of parameters if communications is lost • Staff Back-Up Control Centers (as necessary) • Reassess the allowed level of communications between generators and transmission operators in order to facilitate necessary communications

Terrorism and Sabotage

Communicating Threats

- Electric Sector-Information Sharing and Analysis Center (NERC operated) receives and reviews information from:
 - U.S. or Canadian Federal Agencies
 - Reliability Coordinator
 - Electric Sector Entities (Region, Control Area, Purchasing-Selling Entity)
 - Other Sector ISACs (Oil and gas, chemical, nuclear, aviation, defense, financial services, etc.)
 - If the information is specific and has credibility, the ES-ISAC will contact the involved entity directly

Terrorism and Sabotage

- ES-ISAC will notify other Electricity Sector Entities as appropriate, including:
 - EEI Security Committee (Edison Electric Institute)
 - APPA (American Public Power Association)
 - EPSA (Electric Power Supply Association)
 - NEI (Nuclear Energy Institute)
 - NRECA (National Rural Electric Cooperative Association)
 - CEA (Consumer Electronics Association)

Terrorism and Sabotage

PJM Actions:

- Communicating Threats
 - Timely and clear communications between PJM and its Members, in both directions is KEY in the successful managing of any suspected or actual crisis
 - PJM will monitor the Reliability Coordinator Information System (RCIS) for the presence of sabotage or terror events, and will alert other RC's of events on the PJM system via the RCIS
 - If information is urgent or time-sensitive, a Reliability Coordinator Conference call will be convened

Terrorism and Sabotage

PJM Actions:

- Communicating Threats
 - No information shared by Reliability Coordinators will be passed on without approval
 - No information shared is to be delivered to the public media

Terrorism and Sabotage

Member Actions:

Communicating Threats

- If a PJM Member has been contacted by the ES-ISAC, concerning a threat to their facilities, or has received or observed a sabotage event, contact the PJM Shift Supervisor
 - PJM will then communicate the information to other Reliability Coordinators, via the RCIS
 - PJM will rapidly assess and pass the information to its members via the ALL-CALL for urgent/time sensitive material, or
 - via the SOS or email for general/non-actionable material

Severe Weather Emergencies

Severe Weather Events

Severe Storms

- When storms are in the vicinity of the PJM RTO, automatic re-closing capability should be in service for all EHV and also critical 230 kV and above circuits
- If automatic reclosing is unsuccessful in restoring equipment to service, consideration should be given to additional manual tests
 - Tornadoes, hurricanes, etc. may cause permanent damage to equipment
 - Additional testing should weigh the potential risk to the public from testing downed wires or damaged facilities



Severe Weather Events

PJM Actions:

- Request automatic reclosing capability be put into service on critical facilities
- May request maintenance and testing on critical transmission, generating, control, or monitoring equipment be deferred or cancelled
- Inform affected members of any storms moving into the area
- May implement ***Conservative Operations***

PJM Member Actions:

- Notify PJM Dispatcher of any storms in their systems
- Restore auto-reclosing, or take other actions as instructed by PJM
- Notify PJM any time automatic reclosing is removed from service

Severe Weather Events

Cold Weather Alert:

- Purpose: Prepare personnel and facilities for expected extreme cold weather conditions
- Trigger:
 - When the forecasted weather conditions approach minimum or actual temperatures for a Control Zone fall near or below 10 degrees Fahrenheit
 - AND/OR*
 - At higher temperatures if increased winds are anticipated
 - AND/OR*
 - Expected spot market gas curtailments during load pick-up periods



Severe Weather Events

Cold Weather Alert:

PJM utilizes the following weather locations and approximate unavailability rates to declare Cold Weather Alerts on a PJM Control Area or Control Zone basis

Control Zone	Region	Weather	Unavailability
Mid Atlantic	Mid-Atlantic	Philadelphia	4000 - 5000 MW
FE-South/Duq	Western	Pittsburgh	500 – 1000 MW
AEP	Western	Columbus	1000 – 1500 MW
Dayton	Western	Dayton	500 – 1000 MW
ComEd	Western	Chicago	2000 – 3000 MW
Dominion	Southern	Richmond	1000 – 2000 MW
FE-West	Western	Cleveland	500 – 1000 MW
DEOK	Western	Cincinnati	200 – 300 MW
EKPC	Western	Winchester	200 – 300 MW

Severe Weather Events

PJM Actions:

- Notify PJM management, PJM public information personnel, and members
- Issue Cold Weather Alert, including;
 - Control Zone(s)
 - Forecasted low temperature
 - Forecasted duration of the condition
 - Amount of estimated operating reserve and requirement
 - Whether fuel limited resources are required to be placed into the Maximum Emergency category
- Assume an unavailability factor of 25% to 75% for scheduled interchange

Severe Weather Events

PJM Actions *(con't)*:

- Notify respective generation owners if combustion turbines in excess of 2,000 MW are needed
- If the predicted minimum temperature is -5 degrees F or less, or if there is a significant increase in unit unavailability, increase the level of unavailability of CT Generation, and commit additional reserves to cover
- Confer with generation owners;
 - Instruct them to call in or schedule personnel within sufficient time to ensure that all generators are started and available for loading for the morning pick-up
 - Poll large combined-cycle units regarding projected availability during the reserve adequacy run

Severe Weather Events

PJM Actions *(con't)*:

- Report significant changes in the estimated operating reserve capacity
- Recall/cancel non-critical Generation & Transmission maintenance outages
- Cancel the alert when appropriate

Severe Weather Events

PJM Member Actions:

- Review plans to determine if any maintenance or testing, scheduled or being performed, on any monitoring, control, transmission, or generating equipment can be deferred or cancelled
- Call in or schedules personnel in sufficient time to ensure that all CT and diesel generators that are expected to operate will be started and be available for loading when needed for the morning pick-up
 - Includes operations, maintenance, and technical personnel
 - Units may be run at engine idle or loaded as necessary
- CTs may be started to provide additional Synchronized Reserves
 - Fuel reserves and deliveries will be monitored closely

Severe Weather Events

PJM Member Actions *(con't)*:

- Attempt to start the most troublesome or unreliable units first
- Review combustion turbine capacities, specifically units using #2 fuel oil that do not have sufficient additive to protect them for low temperatures
- Review fuel supplies/delivery schedules
- Monitor and report projected fuel limitations to PJM
- Contact PJM if it is anticipated that spot market gas is unavailable, resulting in unit unavailability
- Contact PJM if there are gas-fired CTs placed in Maximum Emergency Generation due to daily gas limitations of less than 8 hours

Severe Weather Events

Hot Weather Alert

- Purpose: Prepare personnel and facilities for extreme hot and/or humid weather conditions
 - May cause capacity requirements and unit unavailability to be higher than forecast for an extended period of time
- Trigger: When the forecasted maximum or actual temperature for a Transmission zone is at or above 90 degrees* Fahrenheit, with high humidity, for multiple days

(*Temperature trigger is 93 degrees for EKPC and Dominion Zones)

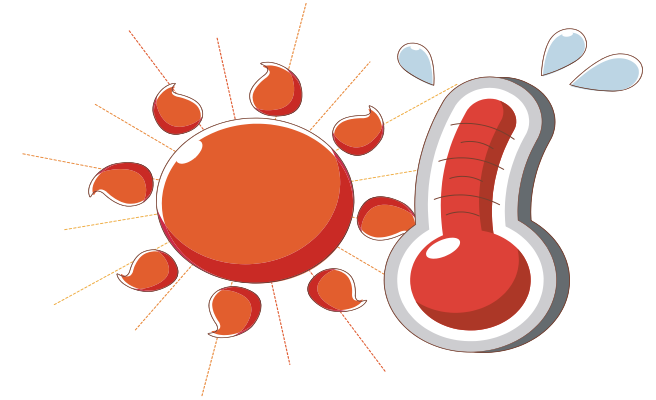

Severe Weather Events

Hot Weather Alert

PJM utilizes the following weather locations and approximate unavailability rates to declare Hot Weather Alerts on a PJM Control Area or Control Zone basis

Control Zone	Region	Weather	Unavailability
Mid Atlantic	Mid-Atlantic	Philadelphia	2000 - 2500 MW
FE-South/Duq	Western	Pittsburgh	300 – 500 MW
AEP	Western	Columbus	500 – 1000 MW
Dayton	Western	Dayton	300 – 500 MW
ComEd	Western	Chicago	1000 – 1500 MW
Dominion	Southern	Richmond	500 – 1000 MW
FE-West	Western	Cleveland	300 – 500 MW
DEOK	Western	Cincinnati	100 – 200 MW
EKPC	Western	Winchester	100 – 200 MW

Severe Weather Events

PJM Actions:

- Notify PJM management and member dispatchers
 - Issue Hot Weather Alert, including;
 - Control Zone(s)
 - Forecasted high temperature
 - Forecasted duration of the condition
 - Amount of estimated operating reserve and requirement
 - Reminder that certain fuel limited resources are required to be placed into the Maximum Emergency category
- Report significant changes in operating reserve capacity
- PJM Dispatch recalls/cancels non-critical Generation & Transmission maintenance outages
- Cancel the alert when appropriate

Severe Weather Events

PJM Member Actions:

- Notify management
- Advise all generating stations and key personnel
- Determine if any maintenance or testing can be deferred or cancelled
- Report to PJM all fuel/environmental limited facilities as they occur, and update as needed
- Contact PJM to inform them of any gas-fired generation placed in Maximum Emergency Generation due to daily gas limitations of less than 8 hours

Voltage Emergencies

Low Voltage Alert

Purpose

- Heighten awareness, increase planning, analysis, and preparation efforts when heavy loads and low voltages are anticipated in an upcoming operation period
 - Issued to Generation and Transmission members
 - Can be issued for the entire PJM RTO, specific Control Zone(s) or a subset of Control Zone(s)

Low Voltage Alert

PJM Actions:

- Conduct power flow analysis of future load and transfer increases on the PJM system
 - Evaluate and plan using the analysis, to include:
 - Ensuring necessary off-cost generation is ready to respond to transfer constraints
 - Consider changing the Reactive Transfer back off limit from 50 MW to 300 MW
- Review generation and transmission outages
- Assess impacts of transfers and be prepared to curtail transactions impacting the reactive transfer limits
- Use NERC Interchange Distribution Calculator, assess the impact of parallel flows
 - Prior to dumping load, PJM will invoke the NERC Transmission Loading Relief (TLR) process to provide relief from these parallel flows
- Enhance reactive reporting from members by requesting a Reactive Reserve Check
- Enhance communications among SOS Transmission members via SOS conference calls

Low Voltage Alert

Member Actions:

- Transmission and Generation members notify their management, stations and key personnel
- Defer and maintenance or testing affecting capacity or critical transmission
- Respond to the Reactive Reserve Check by checking status and availability of all critical reactive resources

Heavy Load Voltage Schedule Warning

Purpose

- Issued to members to prepare for maximum support of voltages on the bulk power system
 - Can be issued for the entire PJM RTO, specific Control Zone(s) or a subset of Control Zone(s)

Heavy Load Voltage Schedule Warning

PJM Actions:

- Issue Heavy Load Voltage Schedule Warning to members 4 hours prior to requesting actual implementation of a Heavy Load Voltage Schedule
- Request members to verify that all actions have been taken on the distribution and sub-transmission system to support voltage at the EHV level

Heavy Load Voltage Schedule Warning

Member Actions:

- Ensure, where possible, while still observing established limits
 - Underlying reactors are out of service
 - Underlying capacitors are in service
 - Transformer taps are adjusted to ensure all distribution capacitors are in service
- Generation Dispatchers ensure that all automatic voltage regulators are in service on generating units

Heavy Load Voltage Schedule Action

Purpose

- Issued to members at peak load periods via the ALL-CALL system to request maximum support of voltages on the bulk power system and increase reactive reserves at the EHV level.
 - Can be issued for entire PJM RTO, specific Control Zone(s) or a subset of Control Zone(s).

Heavy Load Voltage Schedule Action

PJM Actions:

- At peak load period, request all companies implement the Heavy Load Voltage Schedule via the ALL-CALL system
- PJM Dispatch cancels the Heavy Load Voltage Schedule, when appropriate.

Heavy Load Voltage Schedule Action

Member Actions:

- Ensure where possible, while still observing established limits
 - Underlying reactors are out of service
 - Underlying capacitors are in service
 - Capacitors on the 500 kV system with PLCs are in service
- Ensure all unit voltage regulators are in service
- Units on the 230 kV system and below should increase MVAR output as necessary to maintain scheduled bus voltages or nominal voltages, whichever is greater
 - Voltage levels should be maintained within predetermined limits at all times
- Units on the EHV level are operated to maintain a reasonable MVAR reserve
 - Reactive moves on these units should be coordinated with PJM
- Inform PJM of any units approaching max MVAR output, unit MVAR restrictions or AVR's out of service

High System Voltage

Purpose

- Prepare the system for expected high voltages
 - Coordinate with Transmission owners to take steps to control high voltage prior to entering a light load period
- Take actions in real time when portions of the PJM RTO are experiencing a low load/high voltage condition

High System Voltage

PJM Actions:

- Issue High System Voltage message
- Direct all companies to take actions to control high system voltages
- Coordinate with Transmission and Generation owners to direct generators to operate outside voltage schedules

High System Voltage

Member Actions:

- Switchable capacitors are out of service, switchable reactors are in service and SVCs are operating in the lead
- Review and request adjustments to generator excitation (within approved bandwidth) so units absorb reactive power as modeled in the reported unit D-curve
- Review and adjust LTC settings as appropriate
 - All LTC (230 kV and above) and voltage schedule adjustments shall be coordinated with PJM dispatch
- Generation should operate at the lower bandwidth of their voltage schedule when possible
 - Example: A generator following a voltage schedule of 235 kV +/- 4 kV should be operating to 231 kV if possible
- Voltage schedule adjustments or excitation adjustments outside of the approved bandwidth shall be coordinated with PJM
- Generation communicate with PJM and TOs any restrictions on unit ability to absorb MVARs if it varies from reported capability

Reactive Reserve Checks (RRCs)

Reactive Reserve Checks

- Assess RTO and member's dynamic and static reactive power position
- Typically performed prior to Peak conditions
 - May also be needed during light load conditions
 - May be issued once a week for testing purposes
- MVAR reserve expressed as:
 - MVAR available (lagging) to the system for a Peak RRC
 - MVAR available (leading) to be taken off the system for a Valley RRC

Reactive Reserve Checks

- RTO assets include PJM modeled:
 - Generating units
 - Synchronous condensers
 - Static VAR Compensators (SVCs)
 - Capacitors
 - Reactors

Reactive Reserve Checks

- PJM assesses the reactive reserve of the associated equipment via three key metrics:
 - **Capability:** the lagging and/or leading capability for a given piece of equipment
 - Generating units, synchronous condensers and SVCs
 - Lagging/leading MVAR points of Reactive Power Capability Curve are used
 - Capability is a maximum (lagging) and minimum (leading) MVAR range
 - Capacitors and reactors
 - Capability is single MVAR value at unity power factor
 - Maximum (lagging) MVAR for capacitors
 - Minimum (leading) for reactors

Reactive Reserve Checks

- PJM assesses the reactive reserve of the associated equipment via three key metrics:
 - **Status:** the real-time connectivity to the PJM System, and is expressed as Online or Offline
 - When generator is above economic minimum AVR is considered in service/automatic and regulating voltage
 - When synchronous condenser is online and connected to grid AVR is considered in service/automatic and regulating voltage
 - When SVC is connected to grid it is considered to be in automatic mode and regulating voltage

Reactive Reserve Checks

- PJM assesses the reactive reserve of the associated equipment via three key metrics:
 - **Availability/Unavailability:** this is communicated to PJM through the absence of a PJM eDART ticket (availability) or the presence of an eDART ticket (unavailability) which identifies the equipment as being unavailable
 - Members shall provide timely updates to PJM through the appropriate tools regarding any impact to Capability, Status and/or Availability
 - Through telemetry, timely maintaining updates to eDART tickets and/or direct communication with PJM

Reactive Reserve Checks

Reactive Reserve Check (RRC)

- Expectation is that the RRC will be reported as soon as possible
 - Checking the data throughout the day is encouraged

Reactive Reserve Check

PJM Actions:

- PJM will request the RRC via the ALL-CALL
 - They'll also initiate the RRC within the eDART application for the entire PJM CA or on a Control Zone basis, as necessary
- PJM PD will take a snapshot of current PJM EMS reactive data for comparison purposes
- Work with members to resolve/rationalize any reported differences in reactive reserves, or to correct capability data to ensure accurate Contingency Analysis results

Reactive Reserve Check

Member Actions:

Generation Owners

- Outside of an RRC:
 - Report Capability, Status and/or Availability of their reactive equipment
 - Notify TO/PJM regarding unit reactive performance issues, and update eDART as appropriate
- During an RRC:
 - No action required, unless support directly requested by PJM/TO dispatcher

Transmission Owner

- Outside of an RRC:
 - Report Capability, Status and/or Availability of their dynamic/static reactive equipment
 - Review eDART Reactive Capability Curves for units within the TO's zone, and update TO EMS or reconcile deviations with PJM/GO as needed
 - Compare TO EMS information on an equipment level basis to PJM EMS data via the New Reactive Reserve Check: RRC Self-Check form
- During an RRC:
 - TO enters required data in eDART via the eDART RRC Web form or via XML upload

Reactive Reserve Checks

- Capability Examples:

1. **Unit MVAR Reserve** = Total lagging MVAR reserve of all synchronized units.

- For each unit, this is the difference between the amount of MVARs currently being supplied to the system and the total maximum MVAR output of the unit at that MW output

– **Example:** A steam unit is online at 250 MW. It's D-curve data shows that it is capable of providing 80 MVAR of Reactive capability at that power level. It is currently providing 62 MVAR to the system

- The MVAR Reserve for this unit is 18 MVAR (80 – 62 MVAR)

Reactive Reserve Checks

- 2. Condensers/SVCs** = Total lagging MVAR capability of all on-line SVCs and Condensers
- For Synchronous Condensers, this is the difference between the amount of MVARs currently being supplied to the system and the total maximum MVAR output of the condenser
 - For SVCs this is the difference between how many MVARs the SVC is currently supplying to the system (or removing from it) and the total amount of MVARs the SVC can supply

Reactive Reserve Checks

2. Condensers/SVCs *(con't)*

- **Example 1** – A Condenser is online and providing 45 MVARs to the system. Its D-curve data shows that it is capable of providing 50 MVAR of Reactive capability to the system
 - The MVAR Reserve for this condenser is 5 MVAR. (50 – 45 MVAR)
- **Example 2** – A SVC is online and removing 12 MVARs from the system. The SVC is capable of providing from 30 MVAR of leading reserve to 130 MVAR of lagging reserve to the system
 - The MVAR Reserve for this SVC is 142 MVAR
 - 12 MVAR to go from 12 MVAR leading to neutral, then an additional 130 MVAR of lagging reserve

Reactive Reserve Checks

3. **Capacitor/Reactor** = Total MVAR values of all capacitors that can be energized or reactors that can be removed from service

Reactive Reserve Checks

The Transmission Owner then submits the RRC data via eDART



SBTTO
Training/SandBox

- Feedback
- My eDART
- Upload
- Download
- Trans. Tickets
- Black Start
- Telemetry Coordination
- TERM
- Reactive Reserve
- New Reactive Reserve**
- Instantaneous Reserve Check
- PJM Status Report

©2004
PJM Interconnection L.L.C.

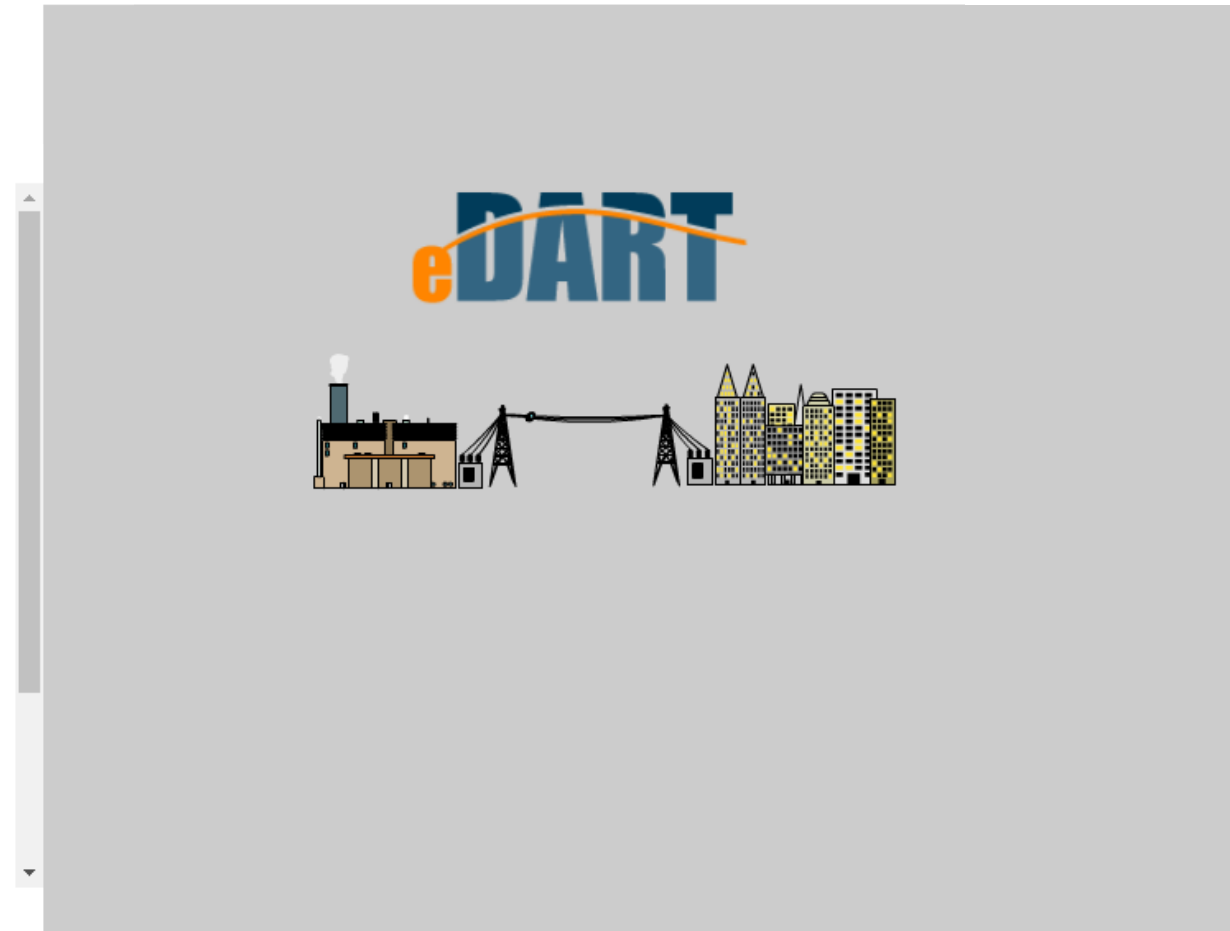

Reactive Reserve Checks

- PJM will compile the results from all TOs, then make a combined report available through eDART
- When there are discrepancies, PJM can make an individual report available to the TO to resolve
- Data will be populated every 5 minutes from PJM's EMS into eDART to allow TO's to do self-checks of the data

Peak MVAR Reserves Self-Check

Company: Request Timestamp: 01/09/2017 13:29
 User Name: student44 Data Updated: 12/02/2016 14:38

Peak (Current)
 Valley

Company	Capacitors	Reactors	SVCs/Statcom	Units/Condensers
AE				
AEP				
APS				
BC				
COMED				
CPP				
DAYTON				
DEOK				
DOM				
DPL				
DUQU				
EKPC				
ENTRGY				
FE				
ITCI				
JC				
ME				
NAEA				
PE				
PEP				
PL				
PN				
PS				
RECO				
SMECO				
SOUTHQ				
UGI				
RTO Total				
Discrepancies Count	0	0	0	122

Capacitors
 Reactors
 SVCs/Statcom
 Units/Condensers

SE Status: Discrepancies Only:

RRC Flow Chart

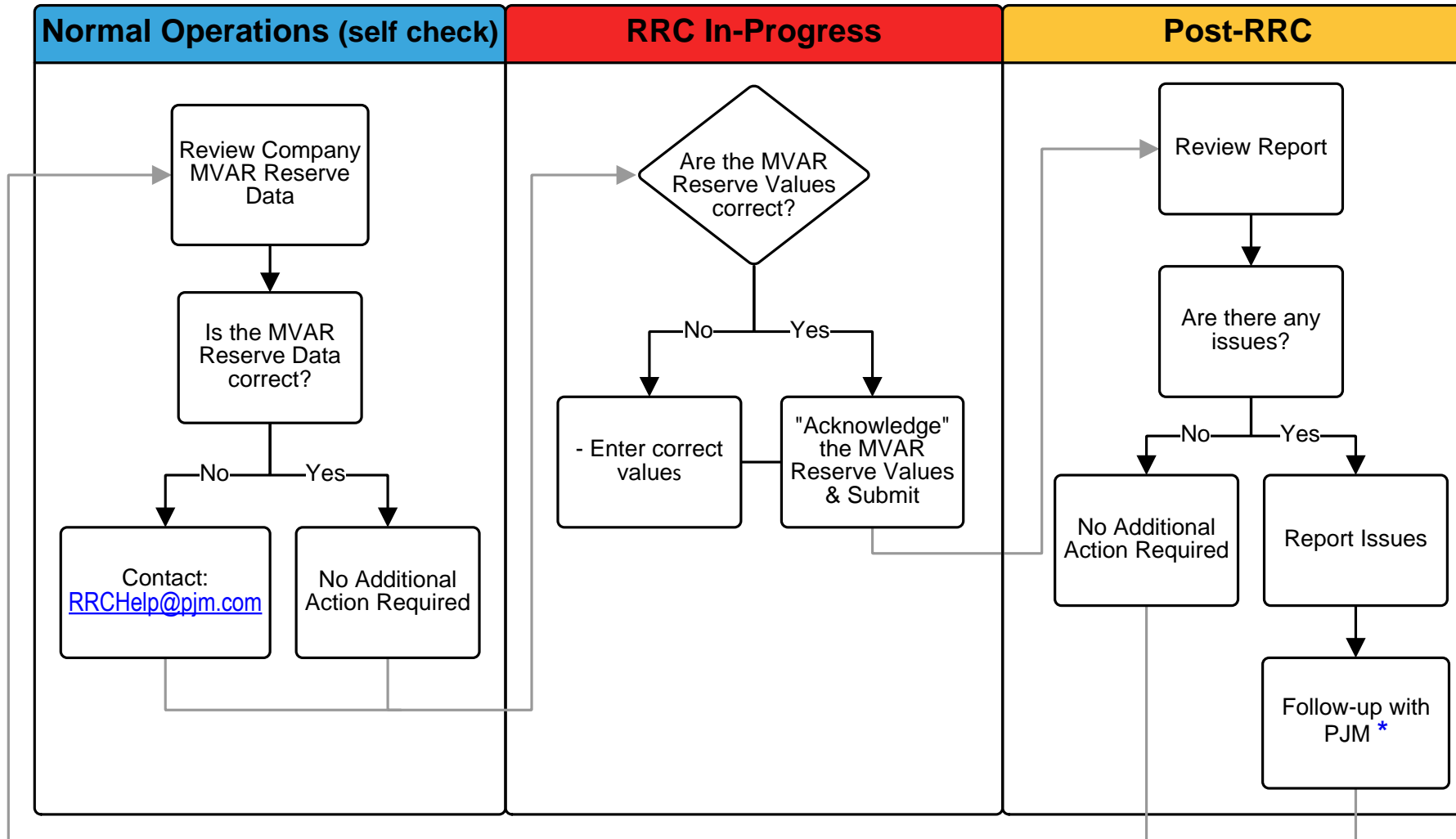

* If the issues involve reserve discrepancies - please contact PJM Dispatch

* If issues involve XML upload, missing units or process questions, please contact: RRCHelp@pjm.com

Discrete Display

Peak MVAR Reserves Self-Check

Company: Test Company Request Timestamp: 02/16/2018 10:50
 User Name: frankp1 Data Updated: 02/16/2018 10:48

Peak (Current) Valley

Company	Capacitors	Reactors	SVCs/Statcom	Units/Condensers
Zone A	0.00	0.00	0.00	0.00
Zone B	2393.80	2131.28	0.00	1036.43
Zone C	1169.80	2328.20	0.00	1044.60
Zone D	395.80	306.60	0.00	191.42
Zone E	3356.48	1208.67	147.55	3273.32
RTO Total	7315.88	5974.75	147.55	5545.77
Discrepancies Count	0	0	0	107

Capacitors Reactors SVCs/Statcom Units/Condensers

SE Status: Both Discrepancies Only:

Apply Sort/Filter
 Refresh
 Main Menu
 Help
 Color Legend

Capacitors

1	2	3	4	5	6	7	8	9	10
Company	Station/Equipment Name	Zone	KV	eDART Availability	SE Status	SE KV	SE MVAR	Rated or Active MVAR	Lagging Reserve MVAR
TC	STATION1 CAP1	Zone A	69	Y	Offline	0.00	0.00	9.60	9.60
TC	STATION2 CAP1	Zone C	138	Y	In-Service	138.48	53.17	53.17	0.00
TC	STATION3 CAP1	Zone D	46	Y	Offline	0.00	0.00	13.20	13.20
TC	STATION4 CAP1	Zone B	138	Y	Offline	143.36	0.00	86.40	86.40
TC	STATION4 CAP2	Zone B	138	Y	Offline	143.36	0.00	86.40	86.40

Discrete Display

Peak MVAR Reserves Self-Check

Company: Test Company Request Timestamp: 02/16/2018 11:08
 User Name: frankp1 Data Updated: 02/16/2018 11:03

Peak (Current) Valley

Zone	Capacitors	Reactors	SVCs/Statcom	Units/Condensers
Zone A	0.00	0.00	0.00	0.00
Zone B	2393.80	2131.28	0.00	1036.43
Zone C	1169.80	2328.20	0.00	1044.60
Zone D	395.80	306.60	0.00	191.42
Zone E	3356.48	1208.67	147.55	3273.32
Company Total	7315.88	5974.75	147.55	5545.77
Discrepancies Count	0	0	0	13

Capacitors Reactors SVCs/Statcom Units/Condensers

SE Status: Both Discrepancies Only:

Apply Sort/Filter
Refresh
Main Menu
Help
Color Legend

Reactors

1	2	3	4	5	6	7	8	9	10
Company	Station/Equipment Name	Zone	KV	eDART Availability	SE Status	SE KV	SE MVAR	Rated or Active MVAR	Lagging Reserve MVAR
TC	STATION1 R1	Zone A	765	Y	In-Service	763.25	-99.54	-99.54	99.54
TC	STATION1 R2	Zone A	765	Y	In-Service	763.25	-99.54	-99.54	99.54
TC	STATION1 R3	Zone A	765	Y	In-Service	763.25	-99.54	-99.54	99.54
TC	STATION2 R1	Zone E	765	Y	Offline	0.00	0.00	-100.00	0.00
TC	STATION2 R2	Zone E	765	Y	Offline	0.00	0.00	-100.00	0.00

Discrete Display

Peak MVAR Reserves Self-Check

Company: Test Company Request Timestamp: 02/16/2018 15:34
 User Name: frankp1 Data Updated: 02/16/2018 15:33

Peak (Current) Valley

Zone	Capacitors	Reactors	SVCs/Statcom	Units/Condensers
Zone A	0.00	0.00	0.00	0.00
Zone B	2393.80	2131.28	0.00	1036.43
Zone C	1169.80	2328.20	0.00	1044.60
Zone D	395.80	306.60	0.00	191.42
Zone E	3356.48	1208.67	147.55	3273.32
Company Total	7315.88	5974.75	147.55	5545.77
Discrepancies Count	0	0	0	13

Capacitors Reactors SVCs/Statcom Units/Condensers

SE Status: Both SE Mode: Both Discrepancies Only:

Apply Sort/Filter
 Refresh
 Main Menu
 Help
 Color Legend

SVCs/Statcom

1	2	3	4	5	6	7	8	9	10	11
Company	Station/Equipment Name	Zone	KV	eDART Availability	SE Status	SE Mode	SE MVAR	Max MVAR	Min MVAR	Lagging Reserve MVAR
TC	STATION1 SVC1	Zone B	138	Y	In-Service	Manual	102.45	250.00	50.00	147.55
In eDART, not mapped to EMS										
TC	STATION2 SVC1	Zone C	138	Y						

Discrete Display

Peak MVAR Reserves Self-Check

Company: Test Company Request Timestamp: 02/16/2018 15:23
 User Name: frankp1 Data Updated: 02/16/2018 15:18

Peak (Current) Valley

Zone	Capacitors	Reactors	SVCs/Statcom	Units/Condensers
Zone A	0.00	0.00	0.00	0.00
Zone B	2393.80	2131.28	0.00	1036.43
Zone C	1169.80	2328.20	0.00	1044.60
Zone D	395.80	306.60	0.00	191.42
Zone E	3356.48	1208.67	147.55	3273.32
Company Total	7315.88	5974.75	147.55	5545.77
Discrepancies Count	0	0	0	13

Capacitors Reactors SVCs/Statcom Units/Condensers

SE Unit Status: Both SE AVR Status: Both Discrepancies Only:

Apply Sort/Filter
Refresh
Main Menu
Help
Color Legend

Units/Condensers

1	2	3	4	5	6	7	8	9	10	11	12	13
Company	Station/Equipment Name	Zone	KV	eDART Availability	eDART AVR Auto	SE Unit Status	SE AVR Status	SE MW	SE MVAR	Max MVAR	Min MVAR	Lagging Reserve MVAR
TC	STATION1 UNIT1	Zone A	69	N/A	Y	In-Service	Manual	0.00	0.00	0.00	0.00	0.00
TC	STATION1 UNIT2	Zone A	69	N/A	Y	In-Service	Manual	0.00	0.00	0.00	0.00	0.00
TC	STATION2 UNIT1	Zone A	138	N/A	Y	In-Service	Manual	2.48	-0.09	0.00	0.00	0.00
TC	STATION3 UNIT1	Zone C	26	N/A	Y	In-Service	Auto	674.82	-80.03	223.31	-181.93	0.00
TC	STATION3 UNIT2	Zone D	26	Y	Y	Offline	Auto	0.00	0.00	0.00	0.00	0.00

Potential Flags

eDART ticket listed as Unavailable and SE MVAR is not 0

Condition:

- Whenever eDART identifies a facility as unavailable, but the PJM EMS SE MVAR output which would indicate that the facility is in-service.

Mismatch between eDART AVR and EMS AVR

Conditions:

- Whenever an eDART AVR ticket exists, but the PJM EMS has the AVR in AUTO (automatic) mode.
- Whenever no eDART AVR ticket exists, but the PJM EMS has the AVR in Manual mode.

Future or Retired Equipment

Conditions:

- Whenever a facility is marked as retired in the eDART database.
- Whenever a facility is marked as future in the eDART database.

Color Legend

- eDART Unavailable and SE MVAR is not 0
- Mismatch between eDART AVR and EMS AVR
- Future or Retired Equipment
- Regular

Close Window

Capacity Emergencies

Capacity Emergencies

A capacity emergency in PJM is defined as:

- Capacity deficiency condition (capacity shortage)
 - Reserve Capability is often triggering event
- Capacity excess condition (light load)

Area	Ancillary Service Market Area	Day-ahead Scheduling (Operating)	Contingency (Primary)	Synchronized Reserve
RTO	RTO	Annual %	150% Largest Single Contingency	Largest Single Contingency
	Mid-Atlantic & Dominion	N/A	150% of the Largest Single Contingency ¹	Largest Single Contingency ¹
SERC	Dominion	VACAR ARS%	VACAR ARS%	VACAR ARS%

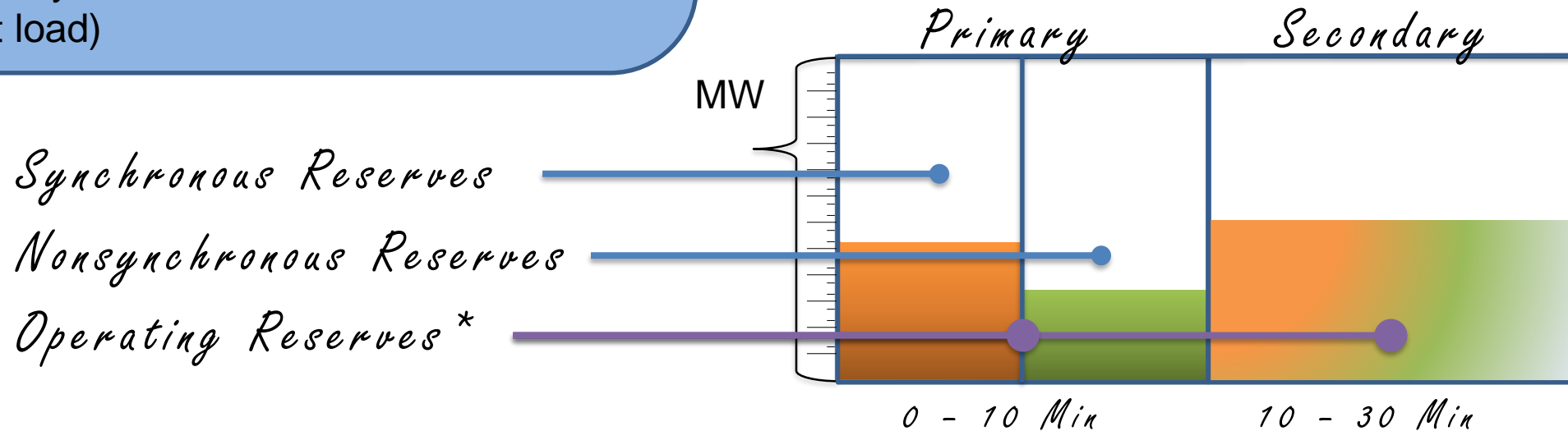

PJM Capacity Emergency Categories

PJM Manual 13, Emergency Operations

PJM is responsible for determining and declaring that an Emergency is expected to exist, exists, or has ceased to exist in any part of the PJM RTO or in any other Control Area that is interconnected directly or indirectly with the PJM RTO.

PJM directs the operations of the PJM Members as necessary to manage, allocate, or alleviate an emergency.

All alerts, warnings, and actions are communicated to Transmission / Generation dispatchers via an ALL-CALL message (and/or, direct operator to operator communication for local events) and posted on selected PJM web-sites. Unless prior agreement is in place with PJM, Transmission Owner dispatchers are responsible for notifying Distribution Providers (DPs), assuring they receive the same information



Capacity Shortage Actions

- Issued real-time and requires PJM and/or Member response
- PJM actions are consistent with NERC EOP standards



Capacity Shortage Warnings

- Issued real-time, typically preceding, and with an estimated time/window for a potential future Action
- Same day of event but prior to Actions being declared



Capacity Shortage / Excess Alerts

- Alerts are issued in advance (Day-Ahead) of a scheduled load period
- Allows sufficient time to prepare for anticipated capacity shortages or excess
- The intent of the alert is to keep all affected system personnel aware of the forecast and/or actual status of the PJM RTO



Capacity Excess Advisories

- Issued one or more days in advance of the operating day
- General in nature and for elevated awareness only.
- No preparations required
- Advisory is not a capacity shortage type at this time, and is used in Light Load Procedures



Alerts

Capacity Shortage Alerts

- Four capacity shortage alerts:
 - Unit Startup Notification Alert
 - Maximum Generation Emergency Alert
 - Primary Reserve Alert
 - Voltage Reduction Alert

Unit Start Up Notification Alert

- Purpose

- To alert members to place generating units in a state of readiness so that they can be brought online within 48 hours in anticipation of a shortage of operating capacity, stability issues or constrained operations

- Trigger

- When a reliability assessment determines that long lead time generation is needed for a future period

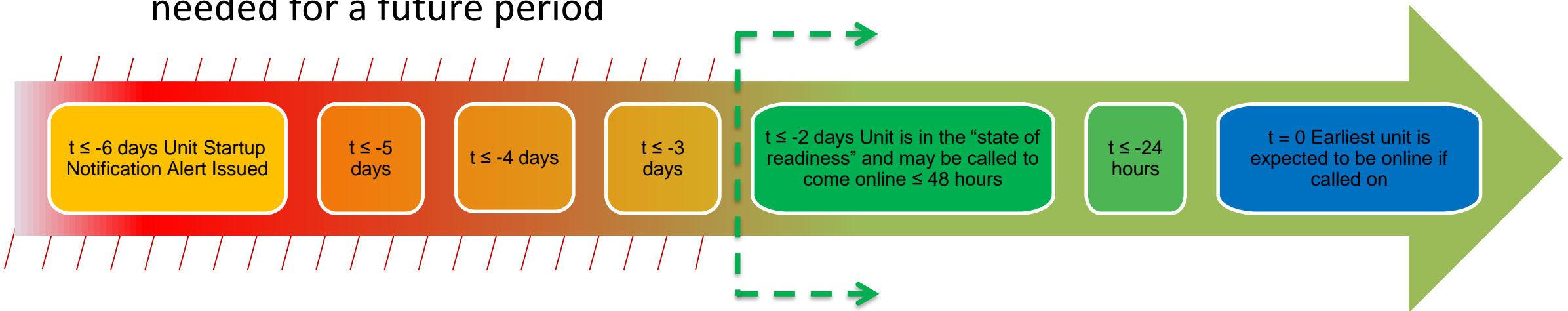

Unit Startup Notification Alert

PJM Actions:

- Notifications to PJM management and member companies
- Schedule an amount of long lead time generation anticipated to be needed for the operating day(s)
 - In economic order
 - Respecting operating parameters
 - Can be issued for the RTO, specific control zone(s) or individual units
- Alerted units must be in a “State of Readiness” in the lesser of;
 - Submitted notification time + startup time – 48 hours
OR
 - 6 days – 48 hours
 - “State of readiness” = able to be online within 48 hours
- Evaluate conditions daily to determine when to release units from the state of readiness, or call the units to come online

Unit Startup Notification Alert

Member Actions:

- Report Unit capabilities correctly
 - Markets Gateway “time to start” maximum is 6 days
- After reaching a “state of readiness”, if the unit fails to come online within 48 hours after being called by PJM, the unit will be considered on a forced outage until it comes online, or PJM cancels the alert
- Once a unit is scheduled, its offer price is locked for the operating day

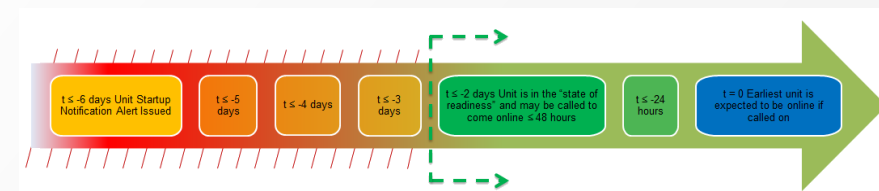

Maximum Generation/Load Management Alert

- Purpose

- To provide an early alert that system conditions may require the use of the PJM Emergency Procedures

- Trigger

- When Maximum Generation Emergency is called into the operating capacity, or if Demand Response is projected to be implemented

- Operating Reserve Requirement* is greater than scheduled Operating Reserve

- Should be issued 1 or more days prior to the operating day in question

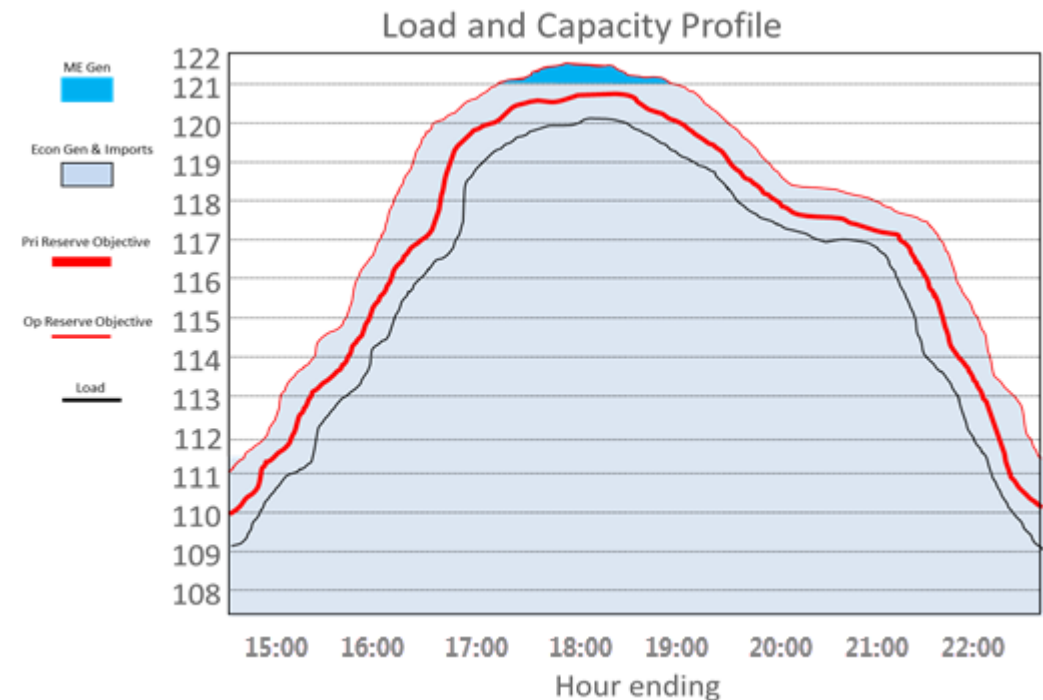

Max Generation / Load Management Alert

PJM Actions:

- Notifications to PJM management and members
 - States the amount of estimated operating reserve and the requirement
 - Issue NERC Energy Emergency Alert Level 1
- Performs a situation analysis and prepares projections for that day and future periods
 - Capacity
 - Interchange
 - Load
 - Reserve
- Reports any significant changes in the estimated operating reserve capacity
- Review the level of dependency on External Transactions to serve PJM load and to determine if the need to implement Capacity Benefit Margin is required

Max Generation / Load Management Alert

Member Actions:

- Notifications
 - Management, all stations, key personnel
- Review plans to determine if any maintenance or testing of equipment, scheduled or being performed, on any monitoring, control, transmission, or generating equipment can be deferred or cancelled
 - Suspend any high risk testing of generating or transmission equipment
- Report any and all fuel/environmental limited facilities as they occur

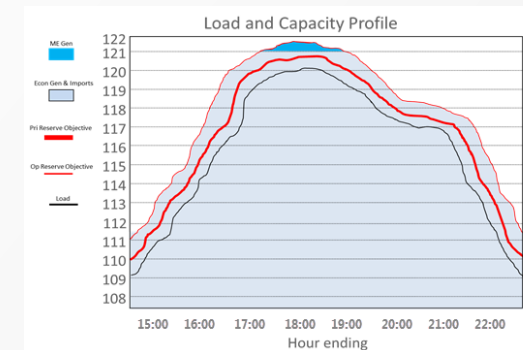

Primary Reserve Alert

- Purpose
 - To alert member of the anticipated shortage of operating reserve capacity for a future critical period
- Trigger
 - When the estimated operating reserve is less than the forecasted primary reserve requirement

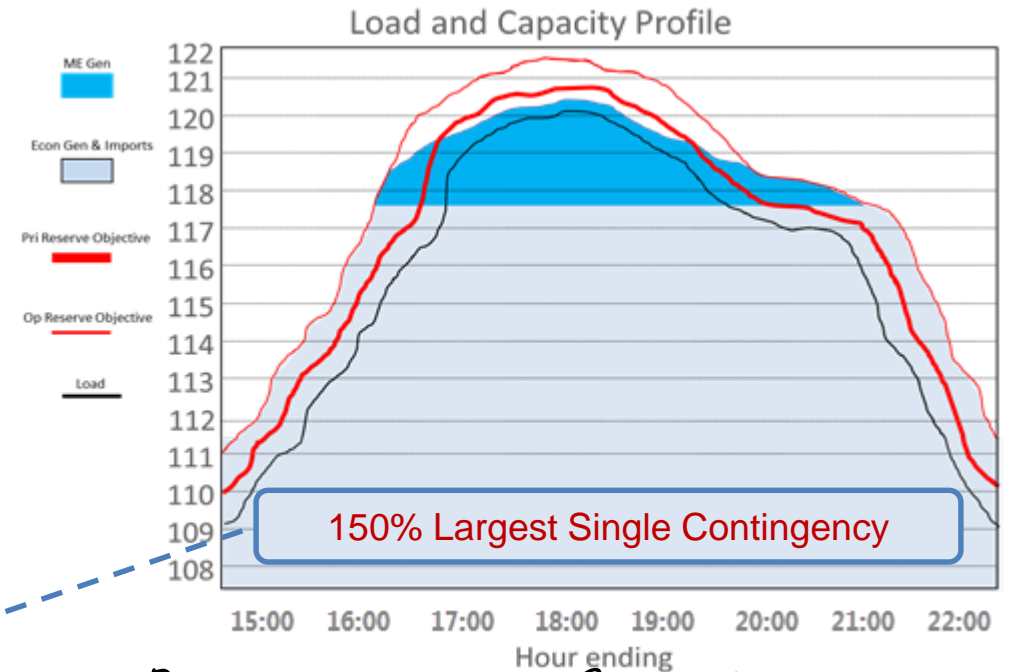

primary reserve requirement

Synchronous Reserves

Nonsynchronous Reserves

*Operating Reserves**

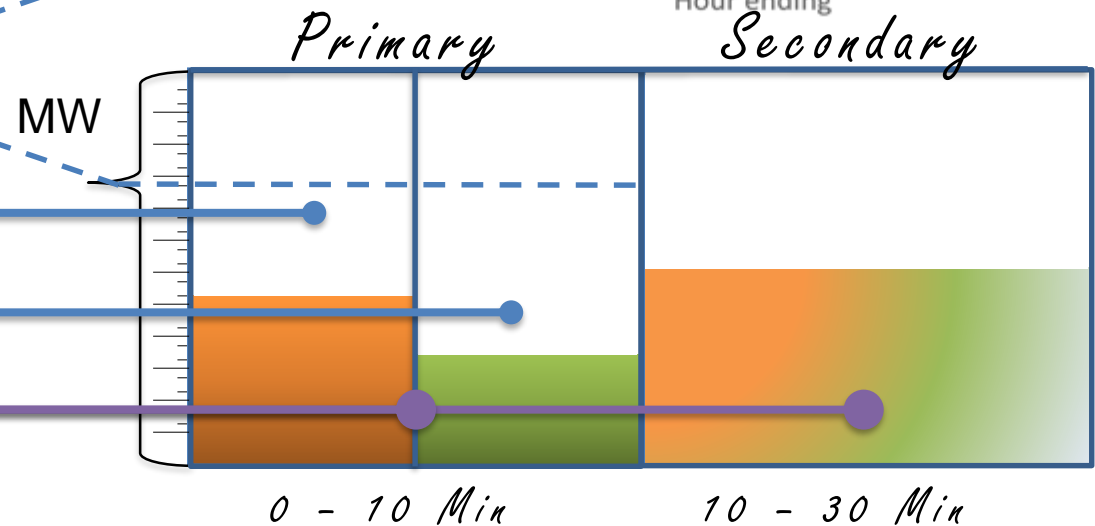

Viewing Current Reserve Requirements on PJM.COM

Tools Sign In Calendar

search

Go



about pjmlibrary

training

commitment

Dispatched Reserves

Cycle Tabs

At a Glance

Ancillary Services MCP

Ties & Interfaces

Renewables

Weather

My Data

Ancillary Services

Operational Reserves

Dispatched Reserves

Last Data Update: 2.13.2018 10:35:00 EST

Reserve Type	RTO (MW)	MidAtlantic / Dominion (MW)
Primary Reserves		
Primary Reserves Requirement	3,559	3,214
Primary Reserves Reliability Requirement	2,218	2,218
Synchronized Reserves	2,028	2,028
Synchronized Reserves Requirement	1,887	1,542
Synchronized Reserves Reliability Requirement	1,542	1,542
Extended Requirement	1,352	1,352
	190	190

Disclaimer: Data provided on this page is based on the real-time security constrained economic dispatch solution, which solves for a near-term look-ahead interval. Reserve pricing, and declaration of shortage pricing, is based upon the data displayed on this page.

Upcoming Meetings

Upcoming Training

- ▶ Liaison Committee Meeting
2.13.2018
- ▶ Subregional RTEP Committee - Western Meeting
2.14.2018
- ▶ Summer-Only Demand Response Senior Task Force Meeting
2.14.2018

- Operational Data
- Data Viewer Guest**
- Data Snapshot
- Maps
- Data Directory
- Emergency Procedures

- Center
- Highway
- Manuals
- Filings
- Careers
- Issue Tracking
- Agreements
- Communication

Primary Reserve Alert

PJM Actions:

- Notifications to PJM management and member companies
 - States the amount of estimated operating reserve capacity and the requirement
- Reports significant changes in estimated operating reserve capacity

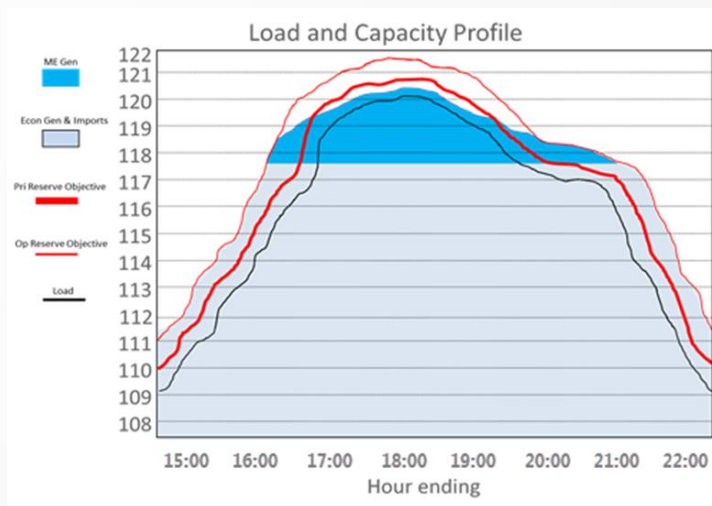

Primary Reserve Alert

Member Actions:

- Notifications
 - Management
 - All stations
 - Key Personnel
- Review plans to determine if any maintenance or testing, scheduled or being performed, on any generating equipment or critical monitoring, control, or bulk power transmission facility can be deferred or cancelled
- Inform PJM of any environmentally restricted units considering the need to obtain a temporary variance from environmental regulators for specific generators to assist in preventing load shed

Voltage Reduction Alert

- Purpose
 - To alert members that a voltage reduction action may be required in a future critical period
- Trigger
 - When the estimated operating reserve capacity is less than the forecasted synchronized reserve requirement

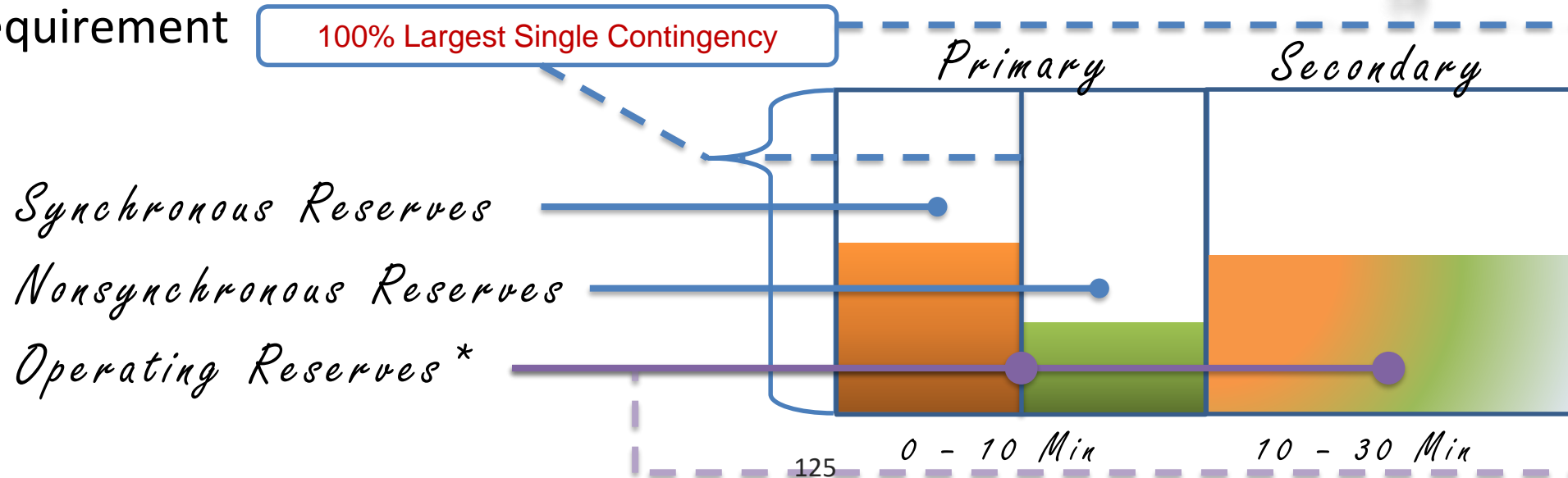
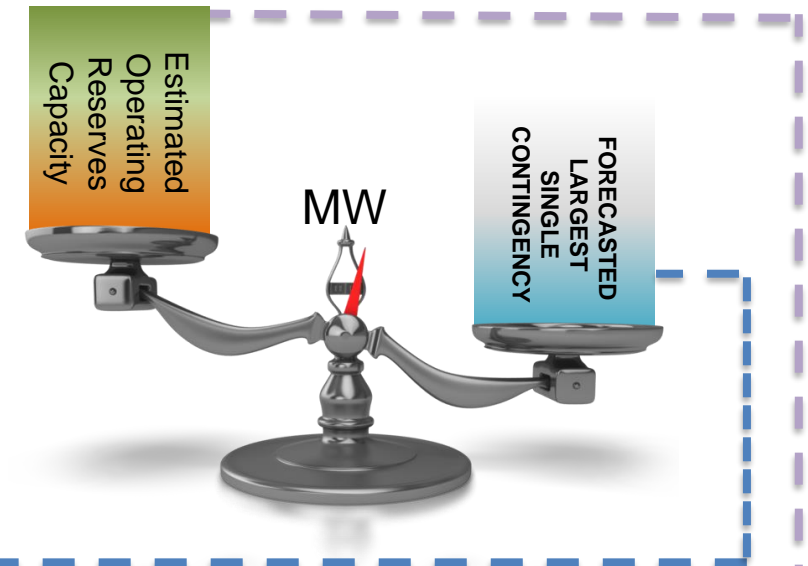

Voltage Reduction Alert

PJM Actions:

- Notifications to PJM management and member companies
 - Stating the amount of estimated operating reserve capacity and the requirement
 - Advise members that a possibility exists that a voltage reduction will be issued and the estimated hour of implementation

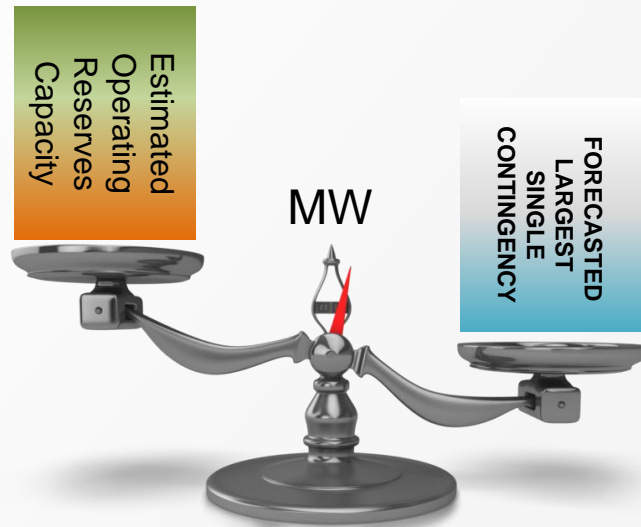

Voltage Reduction Alert

Member Actions:

- Notifications
 - Management
 - All stations
 - Key Personnel
- Take any necessary steps to expedite implementation of voltage reduction, should one become necessary (Transmission Owner Dispatch/LSEs)
- SOS members/PJM Management consider the issuing of Public Appeals
- PJM marketers proceed on heightened awareness regarding potential need for Emergency Energy purchases

Warnings

Capacity Shortages – Warnings

- There are 3 Capacity Emergency Warnings:
 1. Primary Reserve Warning
 2. Voltage Reduction Warning & Reduction of Non-Critical Plant Load
 3. Manual Load Dump Warning

Capacity Shortages – Warnings

- During periods of reserve deficiencies, other measures must be taken to maintain system reliability including:
 - Loading generation that is restricted for reasons other than cost
 - Recalling non-capacity backed off-system sales
 - Purchasing emergency energy from participants / surrounding pools
 - Load relief measures
- Due to system conditions and the time required to obtain results, PJM dispatchers may find it necessary to vary the order of application to achieve the best overall system reliability

Capacity Shortages – Warnings

- Actions taken prior to entering into capacity related Emergency Procedures:
 - Review weather projections, load forecasts, reserve projections and generation performance
 - Ensure LMPs are reflective of system conditions
 - Curtail all non-Firm exports
 - Dispatch may elect to implement an interchange cap to stabilize the amount of interchange during peak hours to protect against volatility

Primary Reserve Warning

- Purpose

- Warning that available Primary reserves are less than required Primary Reserve Requirement and present operations are becoming critical

- Trigger

- Primary Reserve is less than Primary Reserve Requirement but greater than Synchronized Reserve Requirement

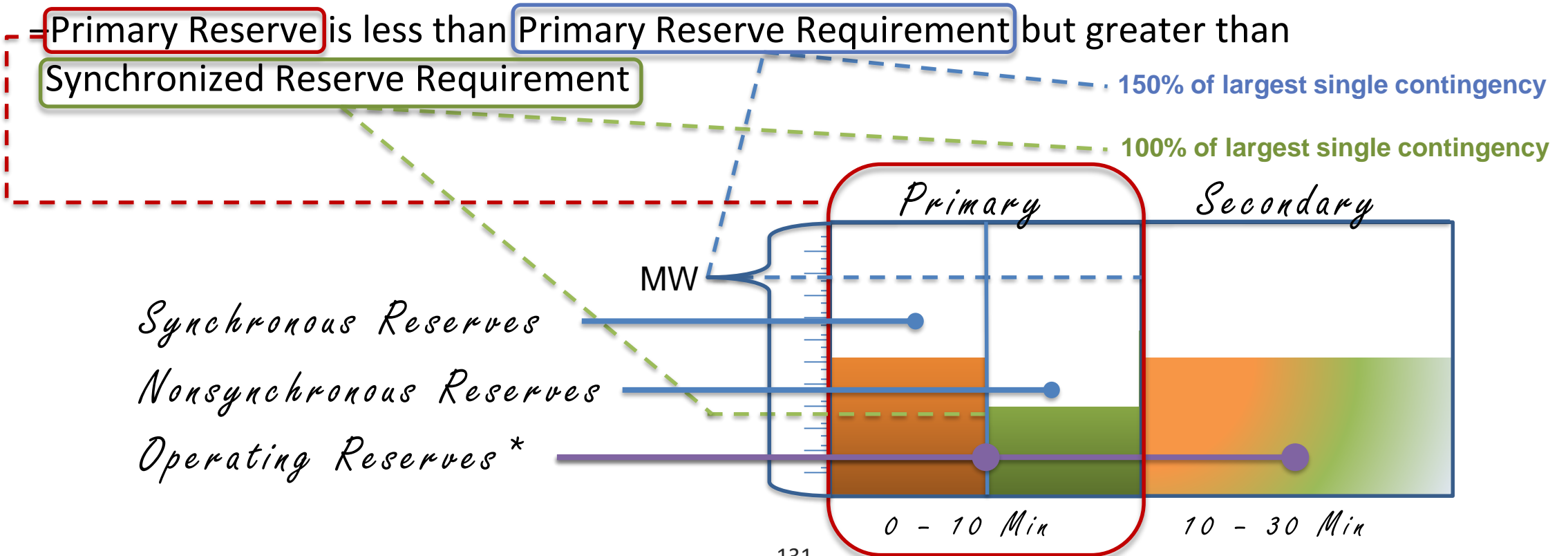

Primary Reserve Warning

PJM Actions:

- State amount of adjusted primary reserve capacity and the requirement
- Assure all available equipment is scheduled and requested secondary reserve brought to primary reserve status
- Ensures applicable deferrable maintenance has been halted
- Notifies PJM public information personnel

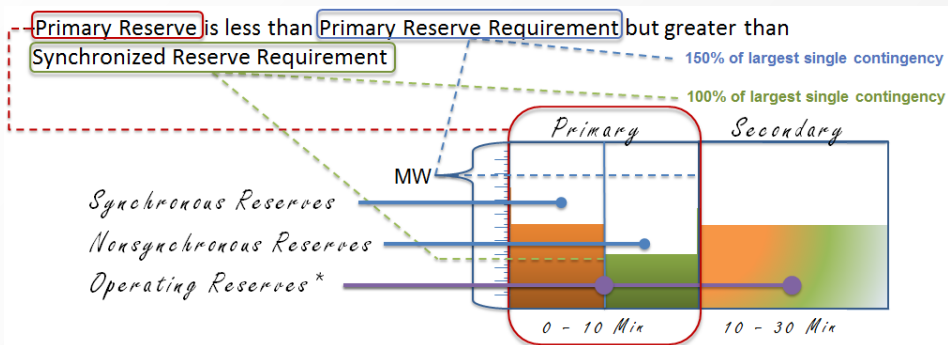

Primary Reserve Warning

Member Actions:

- Notifications
 - Management
 - All stations
 - Key Personnel
- Ensure all deferrable maintenance or testing affecting capacity or critical transmission is halted
- Prepare to load primary reserve, if required
- Inform PJM of any environmentally restricted units
 - If needed, obtain temporary variance to run those generators
- PJM Marketers remain aware regarding the potential need for Emergency Energy Purchases

One of the procedures that triggers a Performance Assessment Interval

Performance Assessment Interval

A Capacity Performance Assessment occurs when one of eleven specific emergency procedures are initiated by PJM system operators. PJM calculates (after-the-fact) the actual performance of capacity resources evaluating real-time production versus their UCAP position, results in bonus payments or penalty charges.

“How well you’re doing versus what you’re committed to do?”

The interval means this assessment occurs every 5 minutes during the assessment period.

Voltage Reduction Warning

Purpose

Warning that available Synchronized Reserves are less than required and present operations may require a voltage reduction. All secondary and primary reserve* is brought to a Synchronized Reserve status and emergency operating capacity is scheduled from adjacent systems

*Excludes Max Emerg Capacity

Trigger

Synchronized Reserves are less than the Synchronized Reserve Requirement and present operations may require a voltage reduction

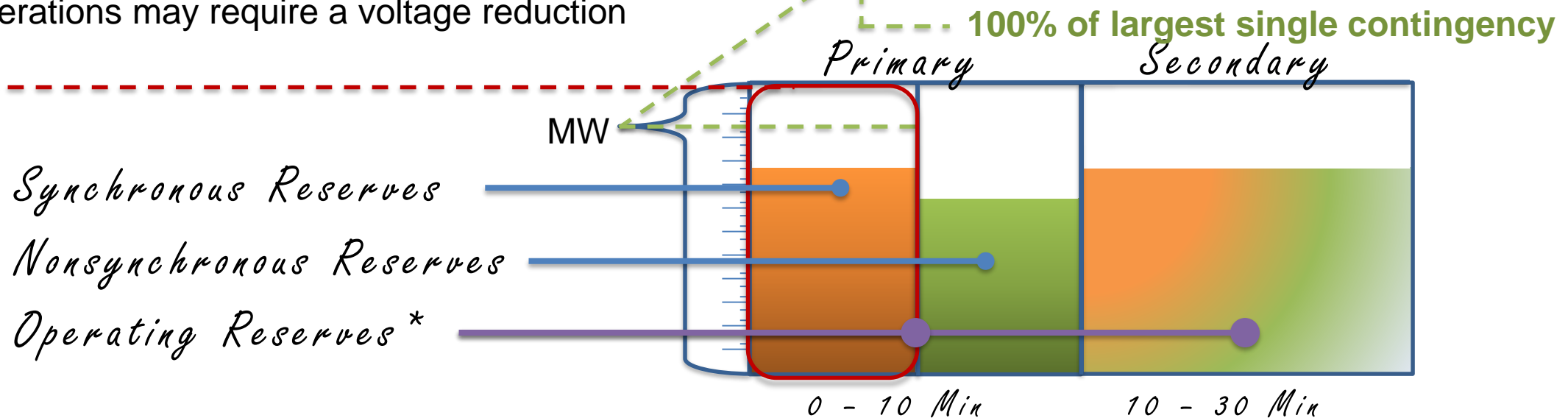

Voltage Reduction Warning

PJM Actions:

- State amount of adjusted synchronized reserve capacity and the requirement
- Notification to Department of Energy (DOE)
- Notifies PJM public information personnel
- All secondary and primary reserve* is brought to a synchronized reserve status and emergency operating capacity is scheduled from adjacent systems

* **Excludes restricted Max Emergency Capacity**

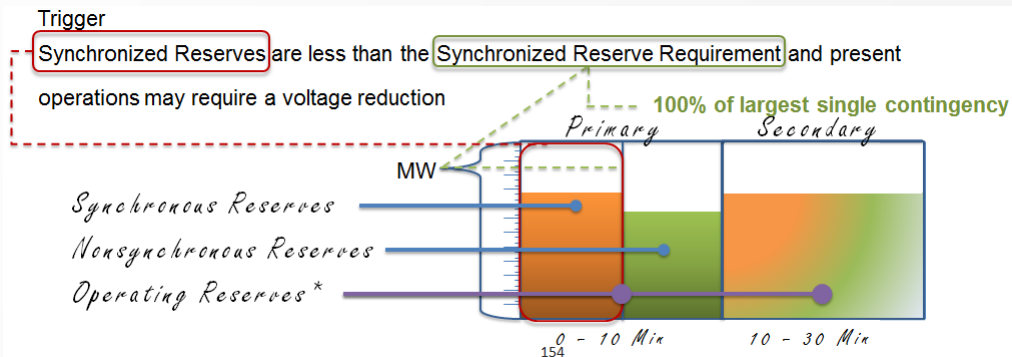

Voltage Reduction Warning

Member Actions:

- Notifications
 - Management
 - All stations
 - Key Personnel
 - Applicable Government Agencies
- Prepare for implementation of Voltage Reduction Action
- Order all generating stations to curtail non-essential station light & power
 - Non-Critical Plant Load is considered anything that is not needed to produce MWs and MVARs on the system
- PJM Marketers remain on a heightened awareness of the potential need for emergency energy purchases
- CSPs – Possible Load Management Action

Manual Load Dump Warning & Curtailment of non-essential building load

Manual Load Dump Warning

Purpose:

Warn Member Companies of increasingly critical system conditions that may require manually dumping load

Trigger:

When the Primary Reserve is less than the largest operating generating unit, or the loss of a transmission facility jeopardizes reliability after all possible measures have been taken to increase reserves

Manual Load Dump Warning

PJM Actions:

- Issue the warning to members and PJM Management, stating the estimated amount of load relief needed
- Notification to PJM public information personnel
- Notification to include the FERC Division of Reliability
- Establish an awareness with the appropriate Transmission Operators of the need for action with minimum delay
- Examine EHV bus voltages

Manual Load Dump Warning

Member Actions:

- Notification to member management
- Notification to government agencies
- Advise all station and key personnel
- Review local procedures and prepare to dump load in the amount requested
- Reinforce internal communications so that load dumping can occur with a minimum delay
- Marketers remain on a heightened awareness of the potential need for Emergency Energy Purchases

Curtailment of Non-Essential Building Load

Purpose:

Provide additional relief, to be expedited prior to, or at the same time as the Voltage Reduction Action

Trigger:

In anticipation or activation of Voltage Reduction Action

Curtailment of Non-Essential Building Load

PJM Actions:

- Notification to PJM Management, PJM public information personnel, and member companies
- Advise members to utilize public appeals to conserve energy
- Issue the request to curtail non-essential building load
- Notify outside systems through the RCIS

Non-Critical Plant Load is considered anything that is not needed to produce MWs and MVARs on the system

Non Critical Plant Load

Lighting
Heating
Air Conditioner
Boom Box

Curtailment of Non-Essential Building Load

Member Actions:

- Notification to member company management
- Notification of government agencies (TO's)
- Consider the use of public appeals to conserve energy
- Switch off all non-essential light and power in company-owned commercial, operations, and administration offices (Transmission and Generation)

Critical Plant Load

Feed Water Heaters
Feed Water Pumps
Induction fans

Actions

Pre-Emergency Load Management Reduction Action

Purpose:

To provide additional load relief by using PJM controllable load management programs (Relief is expected to be required after initiating Maximum Emergency Generation)

- Applies to any site registered in the PJM Demand Response Program as a Demand Resource (a.k.a. DR) type that needs 30, 60 or 120 minute lead time to make its reductions
- Reductions are mandatory when dispatched during the product availability window
- Minimum dispatch duration is 1 hour

Pre-Emergency Load Management Reductions

PJM Actions:

- Notifications to PJM management, public information personnel, and member companies
- Advises Members to use public appeals for conserving electricity usage
- PJM dispatch notifies other Control Areas through the RCIS system
- Via DR Hub and Emergency Procedures website, PJM will post detailed instructions to the Curtailment Service Providers (CSP) to implement
 - Dispatch 30, 60, and/or 120 minute Pre-Emergency Load Management Reductions (Long Lead Time)
- Via the RCIS, PJM issues a NERC Energy Emergency Alert Level 2

Pre-Emergency Load Management Reductions

Member Actions:

- Member Curtailment Service Providers implement load reductions as requested by PJM

Emergency Load Management Reduction Action

Purpose:

To provide additional load relief by using PJM controllable load management programs (Relief is expected to be required after initiating Maximum Emergency Generation)

- Applies to any site registered in the PJM Demand Response Program as a Demand Resource (a.k.a. DR) type that needs 30, 60 or 120 minute lead time to make its reductions
- Reductions are mandatory when dispatched during the product availability window
- Minimum dispatch duration is 1 hour

Emergency Load Management Reductions

PJM Actions:

- Notifications to PJM management, public information personnel, and member companies
- Advises Members to use public appeals for conserving electricity usage
- PJM dispatch notifies other Control Areas through the RCIS system
- Via DR Hub and Emergency Procedures website, PJM will post detailed instructions to the Curtailment Service Providers (CSP) to implement dispatch 30, 60 or 120 minute Emergency Load Management Reductions
- Via the RCIS, PJM issues a NERC Energy Emergency Alert Level 2

Emergency Load Management Reductions

Member Actions:

- Member Curtailment Service Providers implement load reductions as requested by PJM
- Member dispatchers notify management of the emergency procedure and that they should consider the use of public appeals to conserve electricity usage
- Member dispatchers notify governmental agencies, as applicable

Maximum Generation Emergency Action

Purpose:

To increase generation above the maximum economic level

Trigger:

Real-time Generation is needed to meet the load demand that is greater than the highest incremental cost level

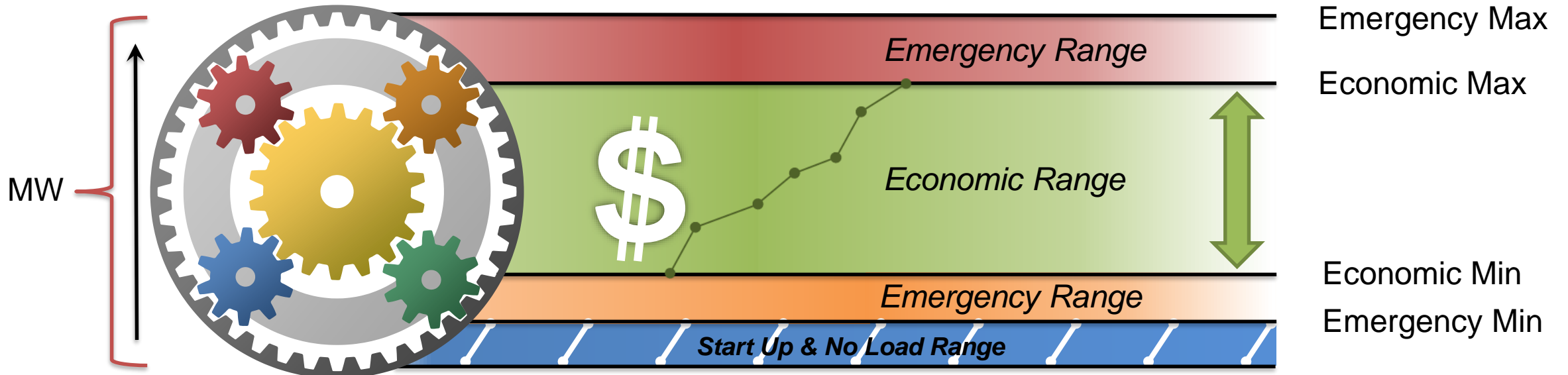
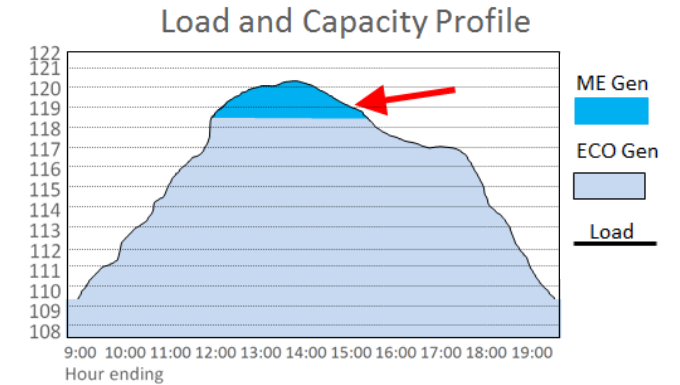

Example Generator Economic vs Emergency Ranging

Maximum Generation Emergency Action

PJM Actions:

- Issue the Maximum Emergency Generation Action
- Notify PJM management, PJM public information personnel, and member dispatchers
- Implements the Emergency Bid Process, requesting bids by posting messages to selected PJM websites, RCIS, and contacting neighboring Control Areas
- Suspend regulation on all resources except for hydroelectric

Maximum Generation Emergency Action

PJM Actions:

- Recalls off-system capacity sales from network resources,

PJM dispatch will:

- Determine any limiting transmission constraints internal to PJM that would impact the ability to cut transactions to a specific interface
- Identify off-system capacity sales associated with the identified interfaces
- Contact the sink Balancing Authority to determine the impact of transaction curtailment

Maximum Generation Emergency

PJM Actions:

- Recalls off-system capacity sales from network resources, if the net result of cutting off-system capacity sales would:
 - Put the sink Balancing Authority into load shed then PJM will not curtail the transactions unless it would prevent load shedding within PJM
 - Put PJM in a more severe capacity emergency than it is in currently in
 - Due to reciprocal transaction curtailments from the sink Balancing Authority
 - PJM will not initiate curtailing the transactions

Maximum Generation Emergency

PJM Actions:

- Declare Maximum Emergency Generation and begins to load Maximum Emergency or start purchases of Emergency Energy bids, based on economics and availability
 - The PJM Member is responsible for delivering (i.e., securing all transmission service) of the energy to one of PJM's borders with a neighboring control area
- Loads Maximum Emergency Generation incrementally as required
- Max Emergency CT's are loaded prior to Max Emergency Steam in order to preserve synchronized reserve

Maximum Generation Emergency

Member Actions:

- Notify member company management
- Recall off-system capacity sales that are recallable
- Suspend regulation, as requested, and load all units to the Maximum Emergency Generation level, as assigned
- Notify PJM of any Maximum Emergency Generation that was loaded prior to PJM requesting Maximum Emergency Generation be loaded

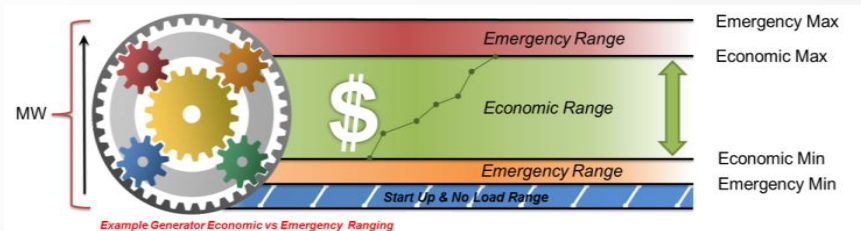

Maximum Generation Emergency

Load and Capacity Profile

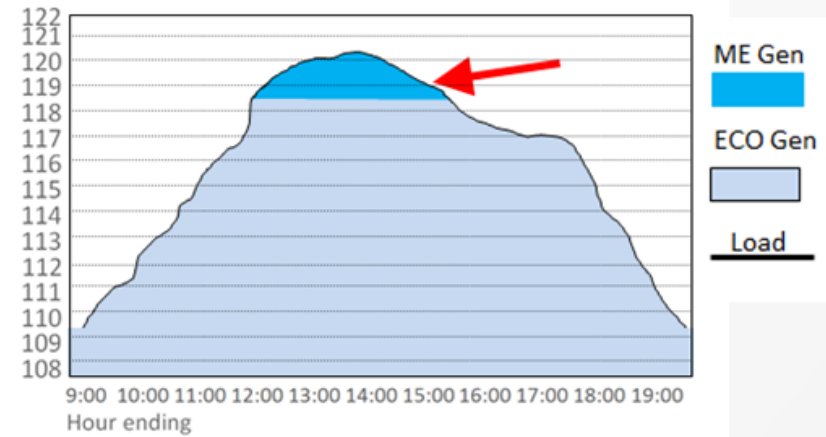

Emergency Voluntary Energy Only Demand Response Reduction Action

Purpose:

Request end-use customers who participate in the Emergency Voluntary Energy Only Demand Response program to reduce load during emergency conditions

Trigger:

Additional load relief is still needed

Program criteria:

Any site registered in the PJM Demand Response Program as an emergency energy only resource
Reductions are strictly **voluntary**

Emergency Voluntary Energy Only Demand Response Reductions

PJM Actions:

- Issues action via the ALL-CALL and posts message on website
- Notifies PJM management, PJM public information personnel, and PJM Markets personnel
- Have Curtailment Service Providers with Demand Resources reduce load

Emergency Voluntary Energy Only Demand Response Reductions

Member Actions:

- Notify management of the emergency procedure

Deploy All Resources Action

Purpose:

To instruct members that all generation resources are needed online and at full output, and

All demand resources are to be reduced immediately upon receipt of dispatch instruction

Trigger:

When unplanned events such as the loss of a transmission or generating facility have resulted in reliable operations being jeopardized

Deploy All Resources

PJM Actions:

- Suspend all reserve assignments and regulation assignments
- Dispatch Load Management via DR Hub
- Recall any external capacity
- Issue a NERC Energy Emergency Alert Level 2 via the RCIS
- Notify PJM Management, PJM public information personnel, and Member Companies

TO

Deploy All Resources

Member TO Actions:

- Notify management of emergency procedures and consider use of public appeals for energy conservation
- Notify applicable government agencies
- Member CSPs with load management reduce load immediately when dispatched

Deploy All Resources

PJM Actions:

- Suspend all reserve assignments and regulation assignments
- Dispatch Load Management via DR Hub
- Recall any external capacity
- Issue a NERC Energy Emergency Alert Level 2 via the RCIS
- Notify PJM Management, PJM public information personnel, and Member Companies



Deploy All Resources

Member GO Actions:

- Unless PJM instructs otherwise
 - Raise ALL available on-line generation and ramp to full output
 - Start off-line generation and ramp to full output
- Notify management of emergency procedures and consider use of public appeals for energy conservation
- Notify applicable government agencies

Voltage Reduction Action

Purpose:

To reduce voltage on the distribution system in order to reduce demand

Provide a sufficient amount of reserve to maintain tie flow schedules and preserve limited energy sources

Trigger:

Load relief still needed to maintain ties

Voltage Reduction:

Voltage is reduced at distribution levels by 2.5% to 5% of nominal values depending on the area

Produces a 2-3% decrease in system load increasing transmission voltages

Generally not being noticed by customers (*lights dimmer, slower heating*)

Voltage Reduction Action

PJM Actions:

- Notification to PJM Management, PJM public information personnel, and member companies
- Advise members to use public appeals for conservation of energy
- Notification to the Department of Energy
- Investigates loading of shared reserves with neighboring systems prior to a voltage reduction action
- PJM dispatch issues a NERC Energy Emergency Alert Level 2
- Issues the order for a 2.5% to 5% voltage reduction
- Initiates Shortage Pricing if the region where the voltage reduction action has been initiated corresponds with an entire Synchronized Reserve Zone or Sub-Zone

Voltage Reduction Action

Member Actions:

- Notification of member company management
- Notification of government agencies
- Consider the use of public appeals to conserve energy
- Take steps to implement a voltage reduction (TO's/LSE's)
- Unless PJM requests a manual adjustment, the Generator must maintain the facility's automatic voltage regulator(s) in service during an Emergency

Manual Load Dump Action

Purpose:

The Manual Load Dump Action is an Operating Instruction from PJM

Trigger:

To shed firm load When the PJM RTO cannot provide adequate capacity

Meet the PJM RTO's load and tie schedules, or

Critically overloaded transmission lines or equipment cannot be relieved in any other way

Manual Load Dump Action

PJM Actions:

- Verify that separations have not occurred and that load dumping is desirable on the system being controlled
- Instruct members to suspend all remaining regulation
- Determine which Control Zone(s) are capacity deficient and the relative proportion of deficiency
- Estimate the total amount of load to be dumped and order appropriate members to dump load according to EMS calculations
- Notification to PJM Management, PJM public information personnel, and member companies
- Advise members to consider the use of public appeals to conserve energy
- Notification to other Control Areas through the RCIS

Manual Load Dump Action

PJM Actions:

- Notifications to DOE, FEMA, and NERC offices
- Notification to FERC via the FERC Division of Reliability's electronic pager system
- Issue a NERC Energy Emergency Alert Level 3
- Initiates Shortage Pricing if the region where the manual load dump action has been initiated corresponds with an entire Synchronized Reserve Zone or Sub-Zone

Note:

- If a partial restoration of the load dumped is requested by PJM, confirmation of restored load by each member must be made prior to any further load restoration
- If UFLS is insufficient to return frequency to acceptable ranges, PJM will dump sufficient load to restore system frequency

Manual Load Dump Action

Member Actions:

- Suspend regulation, as required, prior to load dump
- Notification member company management of the procedure
- Notification of government agencies
- Consider the use of public appeals to conserve energy
- Promptly dump load equal to or in excess of the company's allotment of load dump
- Maintain the requested amount of load relief until the load dump order is cancelled by PJM
- Load dump plan should consider/recognize priority/critical load
- Report amount of load curtailed/restored upon implementation

Manual Load Dump Action

The Process:

- Process described here pertains only to capacity deficient situations
- For transmission constraints or voltage problems, load dump will be ordered in areas where it is most effective
- If Mid-Atlantic region is deemed deficient, total load shed must be further broken down by Manual Load Dump Allocation Tables
 - Manual M-13, Attachment E
- Manual Load Dump last utilized in PJM on January 19, 1994

Attachment E: Manual Load Dump Allocation Tables

Winter/Summer Required Manual Load Dump PJM Mid-Atlantic Region																
MW	PS	PE	PPL Zone		BC	GPU	PEPCO ZONE		AE		DPL Zone					Rockland
			PPL	UGI			PEPCO	SMECO	AECO	Vineland	DPL	ODEC	DEMEC	Dover	Easton	
%	17.54%	14.47%	12.02%	0.32%	11.98%	20.22%	9.89%	1.40%	4.25%	0.26%	4.97%	1.18%	0.42%	0.26%	0.11%	0.70%
500	88	72	60	2	60	101	49	7	21	1	25	6	2	1	1	3
1000	175	145	120	3	120	202	99	14	42	3	50	12	4	3	1	7
1500	263	217	180	5	180	303	148	21	64	4	75	18	6	4	2	10
2000	351	289	240	6	240	404	198	28	85	5	99	24	8	5	2	14
3000	526	434	361	10	360	607	297	42	127	8	149	36	13	8	3	21
4000	702	579	481	13	479	809	396	56	170	10	199	47	17	10	4	28
5000	877	724	601	16	599	1011	495	70	212	13	249	59	21	13	5	35

Manual Load Dump Allocation - PJM Mid-Atlantic Region

When issuing a manual Load Dump via All Call, the PJM Dispatcher will include the following information in the message:

- ✔ (1) Area (PJM Mid-Atlantic Region or a zone / company)
- ✔ (2) Total megawatts (refer to appropriate tables for allocation)
- ✔ (3) Allocation table to be used
- ✔ (4) Transmission Zone allocations will be handled separately based on PJM EMS capacity calculations

Allocation percentages are based on 2016 summer but applicable to both 2016 summer and 2016/2017 Winter Load conditions

Exhibit 9: Manual Load Dump Allocation Tables

PJM Manual Load Dump Capability by company is located in [Manual 13: Attachment F](#)

Capacity Excess Conditions

Capacity Excess Conditions

- When do we have capacity excess?
 - Valley Load
 - If the RTO valley load is projected to be at or below 70,000MWs (Summer/Winter) or 65,000MWs (Spring/Fall)
- Where will the declarations get posted?
 - selected PJM web-sites and the NERC RCIS

Capacity Excess Conditions

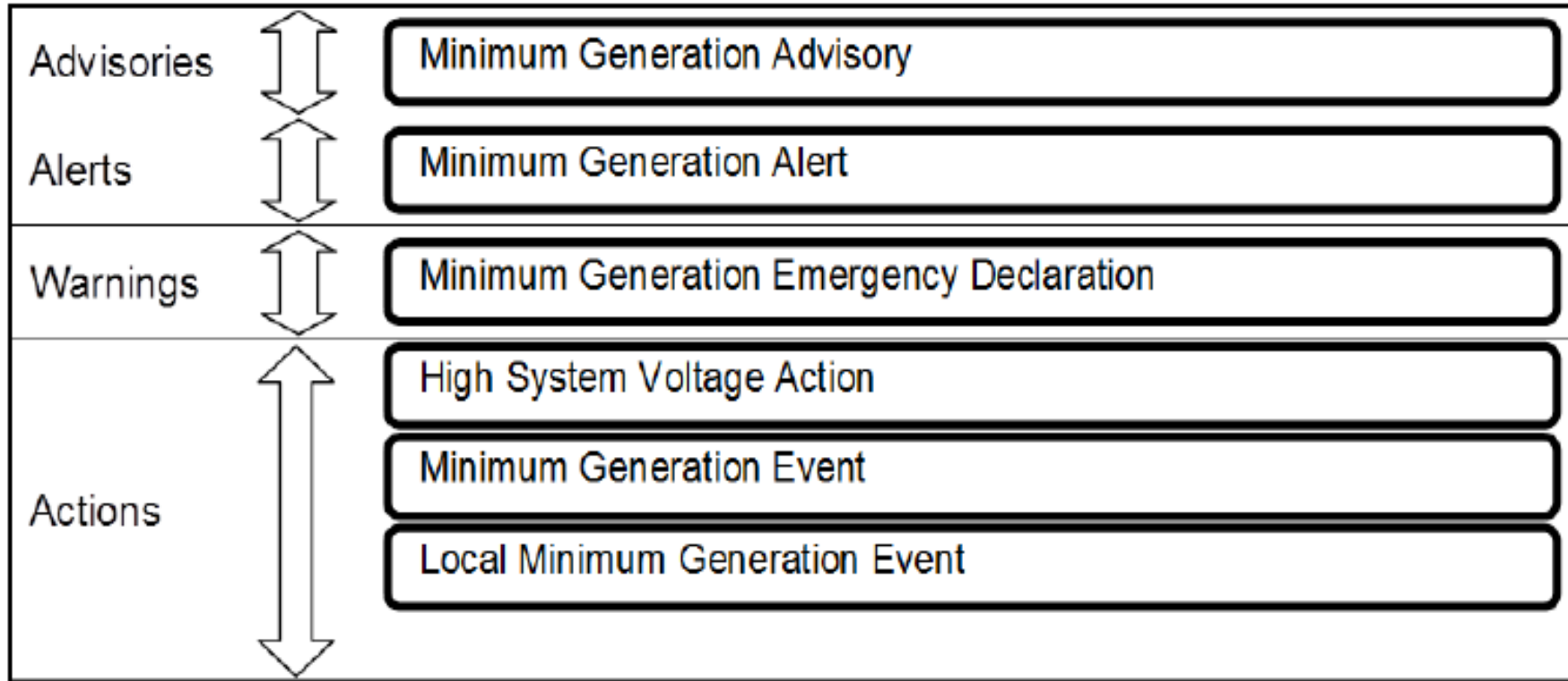

Capacity Excess Conditions

- Light Load Procedures
 - Failure of a Control Area to provide adequate generation control can result in:
 - Deviations in frequency
 - Inadvertent power flow
 - Stability issues
 - Transmission constraints
- For the RTO to meet its control requirements, it may be necessary to deviate from normal operating procedures during light load periods

Potential Phases of a Minimum Generation Event



Questions?

PJM Client Management & Services

Telephone: (610) 666-8980

Toll Free Telephone: (866) 400-8980

Website: www.pjm.com



The Member Community is PJM's self-service portal for members to search for answers to their questions or to track and/or open cases with Client Management & Services

Resources & References



Miller, R. & Malinowski, J. (1994). *Power System Operation*. Boston, MA: McGraw-Hill.

PJM. (2019). *PJM Manual 3: Transmission Operations (rev 55)*. Retrieved from <https://www.pjm.com/~media/documents/manuals/m03.ashx>

PJM. (2019). *PJM Manual 13: Emergency Operations (rev 70)*. Retrieved from <https://www.pjm.com/~media/documents/manuals/m13.ashx>

PJM. (2019). *PJM Manual 14d: Generator Operational Requirements (rev 48)*. Retrieved from <https://www.pjm.com/~media/documents/manuals/m14d.ashx>